

► Our technology. Your success.

Pumps • Valves • Service

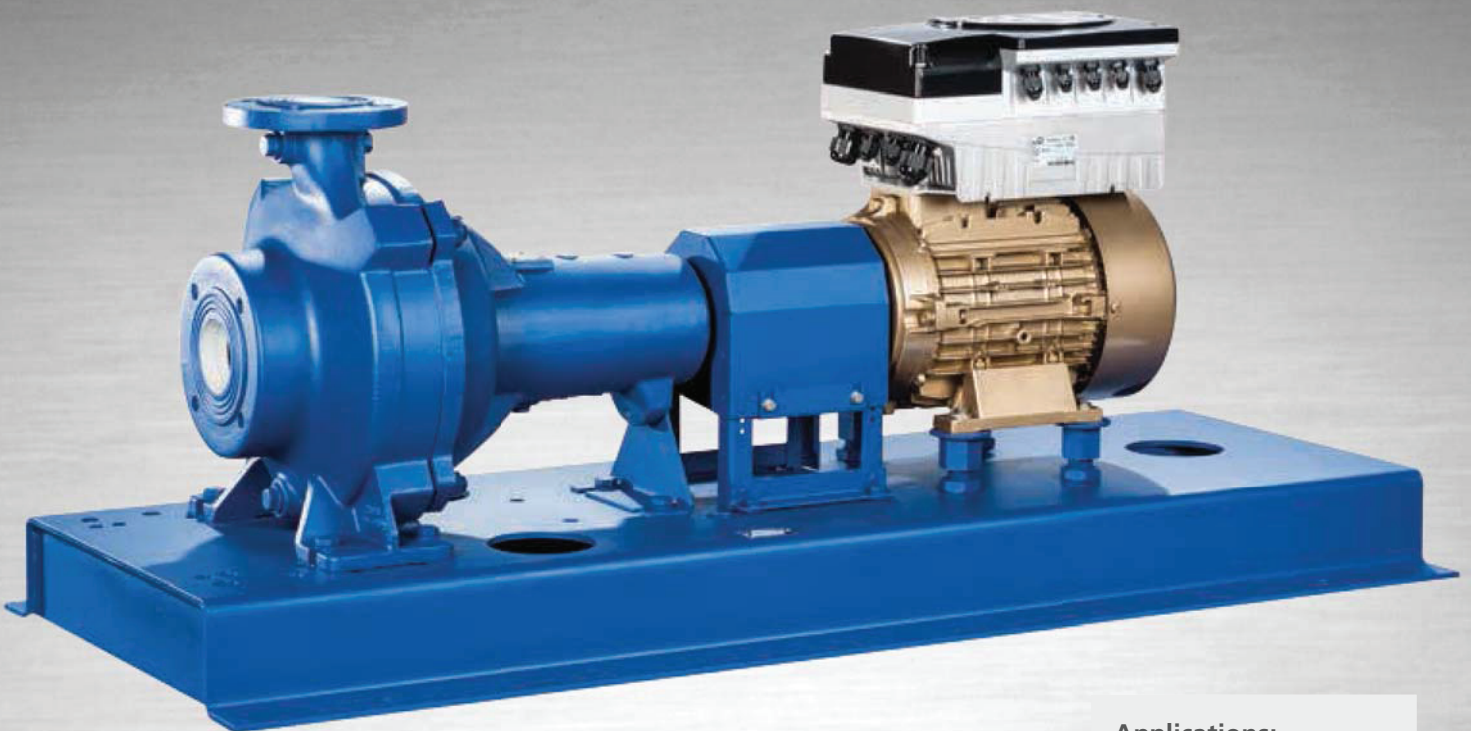

Sewatec/Sewabloc – Waste Water Pump



Applications:

- Waste water transport
- Waste water treatment
- Sludge treatment
- Storm water transport

More information:

www.ksb.com/products

Your contact:



PT. Sukma Tirta Persada
Ruko Asia Tropis (Ruko Grand Boulevard)
Jl. Taman Cemara Blok AT 15 No. 48
Harapan Indah, Bekasi 17214
Tel : (+62-21) 8896 9294 , 8896 9295
Fax: (+62-21) 8865 332
info@sukmatirta.com

www.sukmatirta.com

Sewatec/Sewabloc – Waste Water Pump

- 1 High operating reliability**
Double-acting mechanical seal in tandem arrangement with oil reservoir seals off the pumped fluids
- 2 Cost reduction**
Standardised components are interchangeable within the entire Amarex KRT submersible motor pump series, so spare parts inventories can be optimised
- 3 Low-maintenance design**
Grease-packed rolling element bearings sealed for life
- 4 Variable hydraulic system**
Impellers and casing optimised for handling waste water
- Energy savings**
When combined with the high-efficiency KSB SuPremE® motor, the pump sets make for significantly reduced operating costs
- Variable installation type**
see below

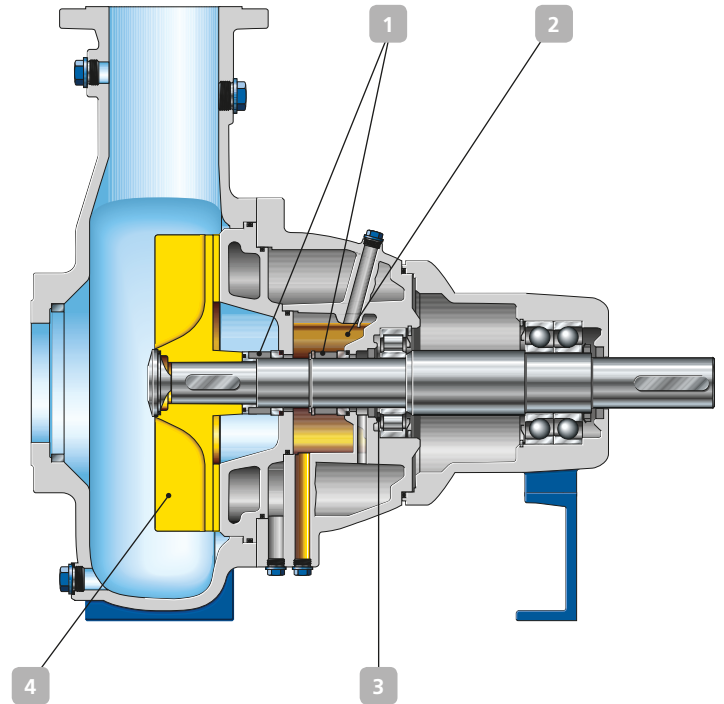

Impellers

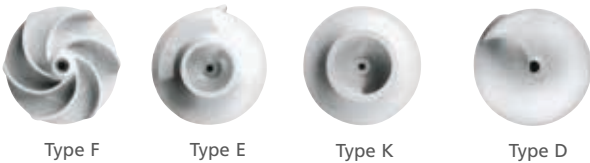

Technical data

Sizes	up to DN 700
Capacity	up to 2,775 l/s
Head	up to 95 m
Discharge pressure	up to 10 bar
Temperature	up to +70 °C

Installation type options

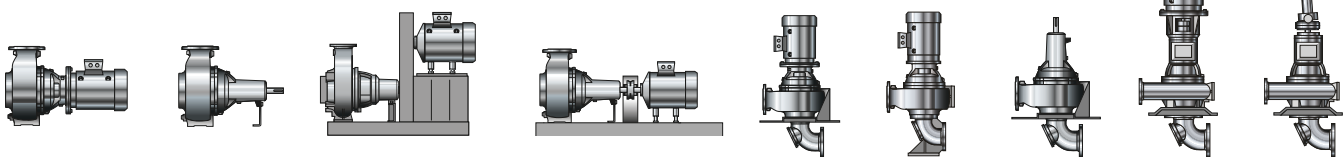

KSB Aktiengesellschaft
Johann-Klein-Straße 9
67227 Frankenthal (Germany)
www.ksb.com