

Dry-installed Volute Casing Pump

KWP

Type Series Booklet



Legal information/Copyright

Type Series Booklet KWP

All rights reserved. The contents provided herein must neither be distributed, copied, reproduced, edited or processed for any other purpose, nor otherwise transmitted, published or made available to a third party without the manufacturer's express written consent.

Subject to technical modification without prior notice.

© KSB Aktiengesellschaft, Frankenthal 18.09.2014

Contents

Centrifugal Pumps with Shaft Seal	4
Dry-installed Volute Casing Pump	4
KWP	4
Main applications	4
Operating data	4
Designation	4
Design details	4
Sizes	7
Automation	7
Material code	7
Material variants	9
Technical data	10
Selection charts	13
Dimensions and connections	16
Coating and preservation	27
Product benefits	27
Acceptance tests / Warranties	27
General assembly drawings with list of components	28
Detailed designation	38

Centrifugal Pumps with Shaft Seal

Dry-installed Volute Casing Pump

KWP



Main applications

Pump for handling pre-treated sewage, waste water, all types of slurries without stringy material and pulps up to 5 % bone dry with a maximum density of 2000 kg/m³.

- Paper and cellulose industry
- Sugar industry
- Food and beverages industry
- Fossil-fuelled power stations
- Chemical industry
- Petrochemical industry
- Flue gas desulphurisation
- Coal upgrading plants
- Industrial effluent treatment systems
- Seawater desalination/reverse osmosis

Operating data

Operating properties

Characteristic		Value
Nominal discharge nozzle diameter	DN [mm]	40 - 900
Flow rate	Q [m ³ /h]	≤ 15,000 ¹⁾
Head	H [m]	≤ 100 ¹⁾
Operating temperature	T [°C]	-40 to +140 ¹⁾
Operating pressure	p [bar]	≤ 10 ¹⁾

1) Higher values on request

Designation

Example: KWPK125-100-0250 GDNG10

Key to the designation

Code	Description	
KWP	Type series	
K	Impeller type	
	K	Channel impeller
	O	Open multi-channel impeller
F	Free-flow impeller	
125	Nominal suction nozzle diameter [mm]	
100	Nominal discharge nozzle diameter [mm]	
250	Nominal impeller diameter [mm]	
GDNG	Material code (⇒ Page 7)	
10	Design variant	

Further information on the designation

(⇒ Page 38)

Design details

Design

- Volute casing pump
- Back pull-out design
- Horizontal installation
- Single-stage
- Single-entry

Pump casing

- Radially split volute casing
- Volute casing with integrally cast pump feet
- Pump casing fitted with a wear plate
- Discharge cover available in the following versions:

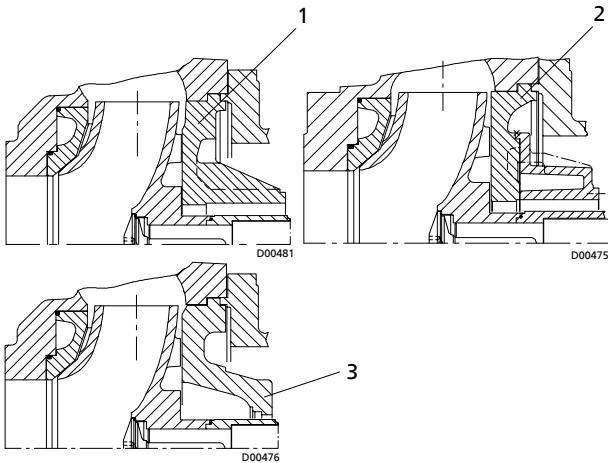

Impeller type

- Back vanes reduce axial thrust.
- Various, application-based impeller types

Discharge cover versions

<p>1 Discharge cover with integrally cast stuffing box housing (cylindrical cover); material variants: GNNG, GDNG, DDDD</p>	<p>2 Discharge cover with bolted stuffing box housing (cylindrical cover, split); material variants: GHHH, HHHH and all sizes on bearing brackets P08sx, P10ax, P12sx for all available materials.</p>
<p>3 For mechanical seal: discharge cover with conical seal chamber (A-type cover); material variants: GNNG, GDNG, DDDD, DKKM, GHHH, HHHH</p>	

Flanges

- Suction flange
 - Up to DN 350 plus 400-400-500, 600-600-824/-825 and 700-700-923/-929: tapped blind hole 1.25 × d, mating dimensions to DIN 2501, PN10 /16 (DN 40 - DN 150), PN10 (DN 200 - DN 350)
 - From DN 400 plus 350-350-500: through-holes to EN 1092-2, PN10
- Discharge flange
 - DN 40 to DN 150: through-holes to EN 1092-2, PN10/16
 - DN 200 and above: through-holes to EN 1092-2, PN10
 - Tapped through-holes DIN 2501, PN10 for 600-600-824/-825, 700-700-923/-929, 700-700-953/-959, 800-800-934/-935/-939, 800-900-883, 900-900-1133/-1134/-1138/-1139

Suction side versions

- Wear plate
 - 065-040-250 to 600-600-669
- Casing wear ring
 - 250-250-315
 - 300-300-400
 - 350-350-400
 - 400-400-500
- Suction cover from 400-400-533

Applications of impeller types

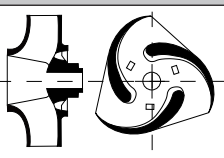
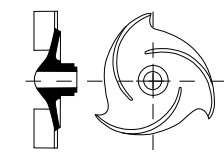
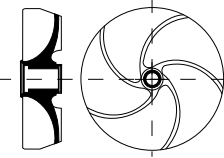
Impeller type	Suitable for the following fluids
 <p>Closed channel impeller (K impeller)</p>	Contaminated, solids-laden fluids not containing stringy material and containing no or very little entrapped gas
 <p>Open multi-vane impeller (O impeller)</p>	For uncontaminated or slightly contaminated fluids as well as fluids liable to form deposits and bunch, with little entrapped gas.
 <p>Open free-flow impeller (F impeller)</p>	Fluids containing larger solids and stringy material as well as fluids with entrapped air or gas

Bearings

- Oil-lubricated rolling element bearings
- Back pull-out design with axially adjustable bearing bracket to adjust the clearance between impeller and wear plate

Bearings used

Standard bearings

Bearing bracket	Rolling element bearing	
	Pump end ²⁾	Drive end ³⁾
P03ax	NU 409	2 x 7309 B-UA
P04ax	NU 411	2 x 7311 B-UA
P05ax	NU 413	2 x 7313 B-UA
P06x	NU 413	2 x 7313 B-UA
P08sx	NU 416	2 x 7319 B-UA
P10ax	NU 324	2 x 7224 B-UA
P12sx	NU 324	2 x 7224 B-UA
P16ax	NU 232 EC3	NU 232 EC3 ²⁾ QJ 328-N2
P20sx	NU 240 E	NJ 238 E ²⁾ 29340-E1 ⁴⁾

Shaft seal

- Shaft fitted with a replaceable shaft protecting sleeve in the shaft seal area
- Gland packing

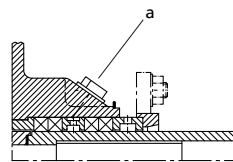

Uncooled gland packing with a) connection for barrier fluid or flushing liquid (connections 10 A.1 and 10 E.1)

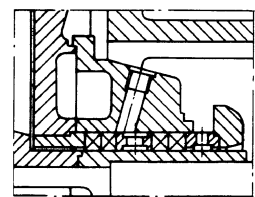

Cooled gland packing

- Commercial single and double mechanical seals

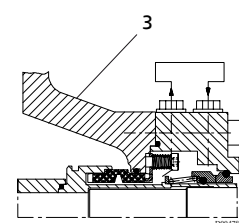
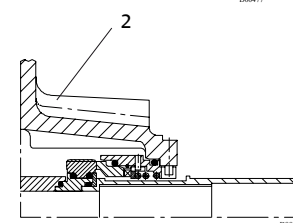
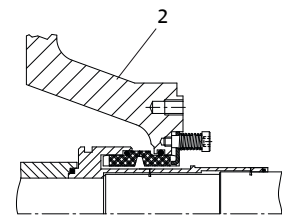
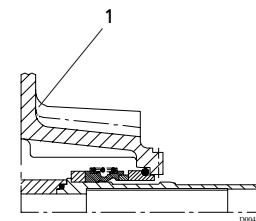

Mechanical seals in conical seal chamber (A-type)

1	Single mechanical seal, unbalanced	2	Single mechanical seal with spring-loaded stationary assembly
3	Mechanical seal in tandem arrangement, with quench		

²⁾ To DIN 5412

³⁾ To DIN 628

⁴⁾ To DIN 728

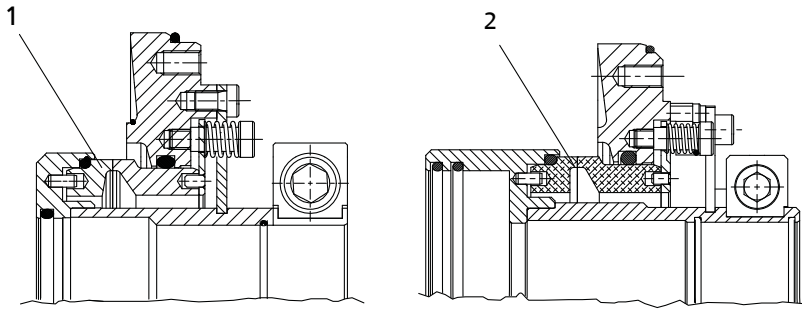

Mechanical seals in conical seal chamber (A-type)

1	Single mechanical seal, balanced, with spring-loaded stationary assembly, bi-directional, for P16ax/P20sx V10	2	Single mechanical seal, with spring-loaded stationary assembly, balanced, bi-directional, for P20sx V11
---	---------------------------------------------------------------------------------------------------------------	---	---------------------------------------------------------------------------------------------------------

Drive

- Electric motor connected to the pump via a coupling or belt drive.

Sizes

Size combinations

Discharge nozzle	Nominal impeller diameter																				
	201	200	251	250 253	311	313 315 320	400 403	500 501 503 504 505	533 583	544	630 633 634 635 637	710 713	663 669 710 753	803 813 814	824 825 873 923	923 929 953 959	934 935 939	883 1133 1134 1138 1139			
	Impeller type																				
	F	K	O	F	K	O	F	K	O	K	O	K	O	K	K	K	K	K	K	K	K
040	-	-	-	-	X	-	-	X	-	-	-	-	-	-	-	-	-	-	-	-	-
050	X	X	X	-	-	-	-	-	X	-	-	-	-	-	-	-	-	-	-	-	-
065	X	X	X	-	-	-	-	X	X	X	-	-	-	-	-	-	-	-	-	-	-
080	-	-	-	X	X	X	X	X	-	X	X	X	-	-	-	-	-	-	-	-	-
100	-	-	-	X	X	X	-	X	-	X	X	-	-	-	-	-	-	-	-	-	-
125	-	-	-	-	-	-	-	-	-	-	-	X	-	-	-	-	-	-	-	-	-
150	-	-	-	-	-	-	X	X	X	X	-	-	-	-	-	-	-	-	-	-	-
200	-	-	-	-	-	-	-	X	-	X	X	X	-	-	-	-	-	-	-	-	-
250	-	-	-	-	-	-	-	X	-	X	-	X	X	-	-	X	-	-	-	-	-
300	-	-	-	-	-	-	-	-	X	-	X	-	-	-	-	-	-	-	-	-	-
350	-	-	-	-	-	-	-	-	X	-	X	-	-	-	X	-	-	-	-	-	-
400	-	-	-	-	-	-	-	-	-	X	-	X	-	X	-	-	-	-	-	-	-
500	-	-	-	-	-	-	-	-	-	-	-	-	-	X	X	-	-	-	-	-	-
600	-	-	-	-	-	-	-	-	-	-	-	-	-	-	-	-	X	X	X	-	-
700	-	-	-	-	-	-	-	-	-	-	-	-	-	-	-	-	-	-	-	X	-
800	-	-	-	-	-	-	-	-	-	-	-	-	-	-	-	-	-	-	-	-	X
900	-	-	-	-	-	-	-	-	-	-	-	-	-	-	-	-	-	-	-	-	X

Automation

Automation options:

- Hyamaster
- hyatronic
- PumpDrive

Material code

Example of material code: DMKM

Key to material code

Code	Description	
D	Casing material	
	G	GJL-250
	D	NORIDUR 1.4593
	H	NORIHARD NH 15 3
	K	GJS-400-18-LT/ CeramikoPolySiC ⁵⁾
M	Impeller material	

5) ≥ 600-600-0824

Code	Description	
	N	ERN
	D	NORIDUR 1.4593
	U	NORIDUR 1.4593 DAS
	H	NORIHARD NH 15 3
	K	CeramikPolySiC®
	M	NORICROM 1.4475
K	Wear plate material	
	N	ERN
	D	NORIDUR 1.4593
	U	NORIDUR 1.4593 DAS
	H	NORIHARD NH 15 3
	K ⁶⁾	CeramikPolySiC®
M	Discharge cover material	
	G	GJL-250
	D	NORIDUR 1.4593
	H	NORIHARD NH 15 3
	K	CeramikPolySiC®
	M	NORICROM 1.4475

⁶⁾ K defines a suction cover in JS-400-18-LT/ CeramikPolySiC for pumps without a separate wear plate

Material variants

Materials

Part No.	Description	Material variant									
		GNNG	GDNG	DDDD	GHHH	HHHH	DUUD	DMKM	DKKM	KUKK	KKKK
101	Pump casing	GJL-250		NORIDUR 1.4593	GJL-250	NORIHARD ⁷⁾	NORIDUR 1.4593 ⁷⁾			GJS-400-18-LT/ CeramikPolySiC ⁷⁾	
135.01	Wear plate, suction side	ERN		NORIDUR 1.4593	NORIHARD		NORIDUR 1.4593/ DAS	CeramikPolySiC			
162	Suction cover	GJL-250		NORIDUR 1.4593	GJL-250	NORIHARD	NORIDUR 1.4593			GJS-400-18-LT/ CeramikPolySiC	
163	Discharge cover	GJL-250		NORIDUR 1.4593	NORIHARD		NORIDUR 1.4593	NORICROM		GJS-400-18-LT/ CeramikPolySiC ⁷⁾	
210	Shaft	C45+N									
230	Impeller	ERN	NORIDUR 1.4593		NORIHARD		NORIDUR 1.4593/ DAS	NORICROM	CeramikPolySiC	1.4593/DAS	CeramikPolySiC
330	Bearing bracket	GJL-250									
344	Bearing bracket lantern	GJL-250									
451.01	Stuffing box housing	GJL-250		NORIDUR 1.4593	GJL-250		NORIDUR 1.4593				
524.01	Shaft protecting sleeve (gland packing)	1.4122 HV500+80		1.4539	1.4122 HV500+80		1.4539				
524.01	Shaft protecting sleeve (mechanical seal)	1.4539									
906	Impeller screw ⁸⁾	C35E+N		NORIDUR 1.4593	C35E+N		NORIDUR 1.4593				

7) Without auxiliary connection bores (drain hole and pressure gauge connection)

8) Bearing bracket P08sx and above: impeller hub cap 260

Technical data

Technical data of hydraulic system

Sizes	Bearing bracket	Impeller type K			Impeller type O			Impeller type F		
		Free passage	Impeller diameter		Free passage	Impeller diameter		Free passage	Impeller diameter	
			max.	min.		max.	min.		max.	min.
		[mm]	[mm]	[mm]	[mm]	[mm]	[mm]	[mm]	[mm]	[mm]
065-040-0250	P03ax	15	260	170	-	-	-	-	-	-
065-050-0200	P03ax	34	209	120	30	209	160	-	-	-
065-050-0201	P03ax	-	-	-	-	-	-	45	209	130
080-065-0200	P03ax	46	209	145	30	209	160	-	-	-
080-065-0201	P03ax	-	-	-	-	-	-	55	209	145
080-040-0315	P04ax	15	320	230	-	-	-	-	-	-
080-050-0400	P04ax	15	408	330	-	-	-	-	-	-
080-065-0315	P04ax	42	320	230	25	320	230	-	-	-
080-065-0313	P04ax	15	320	230	-	-	-	-	-	-
080-065-0400	P04ax	34	408	330	-	-	-	-	-	-
100-080-0250	P03ax	50	260	170	36	260	170	-	-	-
100-080-0251	P03ax	-	-	-	-	-	-	60	260	170
100-080-0311	P04ax	-	-	-	-	-	-	50	320	260
100-080-0315	P04ax	44	320	260	-	-	-	-	-	-
100-080-0400	P05ax	46	404	280	28	404	280	-	-	-
100-080-0403	P05ax	16	404	280	-	-	-	-	-	-
125-080-0500	P06x	20	504	380	-	-	-	-	-	-
125-100-0250	P04ax	60	260	180	50	260	180	-	-	-
125-100-0251	P04ax	-	-	-	-	-	-	50	260	180
125-100-0253	P04ax	28	260	180	-	-	-	-	-	-
125-100-0315	P04ax	54	320	230	-	-	-	-	-	-
125-100-0400	P05ax	50	404	280	35	404	280	-	-	-
125-100-0403	P05ax	20	404	280	-	-	-	-	-	-
150-125-0500	P06x	50	504	350	-	-	-	-	-	-
150-125-0503	P06x	21	509	350	-	-	-	-	-	-
150-150-0311	P05ax	-	-	-	-	-	-	90	320	260
150-150-0315	P05ax	88	320	260	65	320	260	-	-	-
150-150-0400	P05ax	64	404	320	-	-	-	-	-	-
150-150-0403	P05ax	41	404	320	-	-	-	-	-	-
200-200-0320	P05ax	75	320	257	-	-	-	-	-	-
200-200-0400	P06x	80	403	320	78	404	320	-	-	-
200-200-0403	P06x	40	404	320	-	-	-	-	-	-
200-200-0500	P08xs, P10ax, P12sx	75	504	400	-	-	-	-	-	-
200-200-0501	P08xs, P10ax, P12sx	75	504	400	-	-	-	-	-	-
200-200-0503	P08xs, P10ax, P12sx	40	504	400	-	-	-	-	-	-
250-250-0315	P06x	70	324	285	-	-	-	-	-	-
250-250-0400	P08xs, P10ax	80	409	338	-	-	-	-	-	-
250-250-0403	P08xs, P10ax	44	409	340	-	-	-	-	-	-
250-250-0500	P08xs, P10ax, P12sx	85	504	400	70	504	400	-	-	-
250-250-0503	P08xs, P10ax, P12sx	48	504	400	-	-	-	-	-	-
250-250-0505	P08xs, P10ax, P12sx	70	504	436	-	-	-	-	-	-
250-250-0630	P08xs, P10ax, P12sx	86	630	500	-	-	-	-	-	-
250-250-0634	P08xs, P10ax, P12sx	41	630	480	-	-	-	-	-	-
300-300-0400	P08xs, P10ax	85	409	320	-	-	-	-	-	-
300-300-0500	P08xs, P10ax, P12sx	89	504	400	-	-	-	-	-	-
300-300-0503	P08xs, P10ax, P12sx	50	504	420	-	-	-	-	-	-
350-350-0400	P08xs, P10ax	110	408	330	-	-	-	-	-	-
350-350-0500	P08xs, P10ax, P12sx	110	508	390	-	-	-	-	-	-
350-350-0503	P08xs, P10ax, P12sx	65	508	472	-	-	-	-	-	-
350-350-0504	P08xs, P10ax, P12sx	55	507	460	-	-	-	-	-	-
350-350-0630	P08xs, P10ax, P12sx	135	630	500	-	-	-	-	-	-
350-350-0633	P08xs, P10ax, P12sx	75	630	500	-	-	-	-	-	-
400-400-0500	P08xs, P10ax, P12sx	123	508	430	-	-	-	-	-	-
400-400-0503	P08xs, P10ax, P12sx	90	508	445	-	-	-	-	-	-
400-400-0533	P10ax, P12sx	90	538	496	-	-	-	-	-	-

Sizes	Bearing bracket	Impeller type K			Impeller type O			Impeller type F		
		Free passage	Impeller diameter		Free passage	Impeller diameter		Free passage	Impeller diameter	
			max.	min.		max.	min.		max.	min.
		[mm]	[mm]	[mm]	[mm]	[mm]	[mm]	[mm]	[mm]	[mm]
400-400-0583	P10ax, P12sx	90	600	550	-	-	-	-	-	-
500-400-0710	P10ax, P12sx, P16ax	160	730	630	-	-	-	-	-	-
500-400-0713	P10ax, P12sx, P16ax	65	730	630	-	-	-	-	-	-
500-500-0544	P10ax, P12sx	75	572	495	-	-	-	-	-	-
500-500-0630	P10ax, P12sx, P16ax	142	636	528	-	-	-	-	-	-
500-500-0633	P10ax, P12sx, P16ax	90	636	534	-	-	-	-	-	-
500-500-0634	P10ax, P12sx, P16ax	85	636	554	-	-	-	-	-	-
500-500-0635	P10ax, P12sx, P16ax	75	636	565	-	-	-	-	-	-
500-500-0637	P10ax, P12sx, P16ax	85	636	540	-	-	-	-	-	-
600-600-0663	P12sx	80	700	620	-	-	-	-	-	-
600-600-0669	P12sx	80	700	630	-	-	-	-	-	-
600-600-0710	P12sx, P16ax	165	716	650	-	-	-	-	-	-
600-600-0753	P16ax	112	750	675	-	-	-	-	-	-
600-600-0803	P16ax	100	780	718	-	-	-	-	-	-
600-600-0813	P16ax	95	830	710	-	-	-	-	-	-
600-600-0824	P16ax	95	794	720	-	-	-	-	-	-
600-600-0825	P16ax	95	800	709	-	-	-	-	-	-
600-600-0873	P16ax	97	880	800	-	-	-	-	-	-
600-600-0923	P20sx	113	930	840	-	-	-	-	-	-
700-700-0923	P20sx	115	870	765	-	-	-	-	-	-
700-700-0929	P20sx	100	870	780	-	-	-	-	-	-
800-700-0953	P20sx	110	940	834	-	-	-	-	-	-
800-700-0959	P20sx	105	940	820	-	-	-	-	-	-
800-800-0934	P20sx	115	950	845	-	-	-	-	-	-
800-800-0935	P20sx	155	940	850	-	-	-	-	-	-
800-800-0939	P20sx	86	950	854	-	-	-	-	-	-
800-900-0883	P20sx	155	855	750	-	-	-	-	-	-
900-900-1133	P20sx	140	1120	1018	-	-	-	-	-	-
900-900-1134	P20sx	150	1120	1008	-	-	-	-	-	-
900-900-1138	P20sx	120	1122	1006	-	-	-	-	-	-
900-900-1139	P20sx	110	1120	980	-	-	-	-	-	-

Technical data of bearing bracket

Bearing bracket	Gland packing						Shaft diameter				Shaft protecting sleeve		Bearings	
	Bore diameter	Length	Packing ring dimensions	Number of packing rings	Width of lantern ring	Clearance for removing the gland packing	In stuffing box housing	At bearings		At coupling	Gland packing	Mechanical seal	Pump end	Drive end
								Pump end	Drive end					
[mm]	[mm]	[mm]	[Qty]	[mm]	[mm]	[mm]	[mm]	[mm]	[mm]	[mm]	[mm]			
P03ax	65	64	10 x 10	4	20	80	33	45	45	32	45	Depending on make	NU 409	2 x 7309 B-UA
P04ax	75	64	10 x 10	4	20	65	42	55	55	42	55		NU 411	2 x 7311 B-UA
P05ax	95	79	12,5 x 12,5	4	25	75	53	65	65	48	70		NU 413	2 x 7313 B-UA
P06x	95	79	12,5 x 12,5	4	25	75	65	65	65	60	80		NU 413	2 x 7313 B-UA
P08sx	103	132	16 x 16	4	30	105	80	80	95	75	100		NU 416	2 x 7319 B-UA
P10ax	103	152	16 x 16	4	30	105	100	120	120	95	120		NU 324	2 x 7324 B-UA
P12sx	103	172	16 x 16	4	30	105	120	120	120	110	140		NU 324	2 x 7324 B-UA
P16ax	9) ⁹⁾	9) ⁹⁾	9) ⁹⁾	9) ⁹⁾	9) ⁹⁾	9) ⁹⁾	9) ⁹⁾	160	160/140	120	9) ⁹⁾		NU 232	NU 232/ QJ 328
P20sx	9) ⁹⁾	9) ⁹⁾	9) ⁹⁾	9) ⁹⁾	9) ⁹⁾	9) ⁹⁾	9) ⁹⁾	200	200/190	145	9) ⁹⁾		NU 240	29340/ NJ 238
													E	

⁹⁾ Values on request

Selection charts

KWP, K impeller, n=2900 rpm

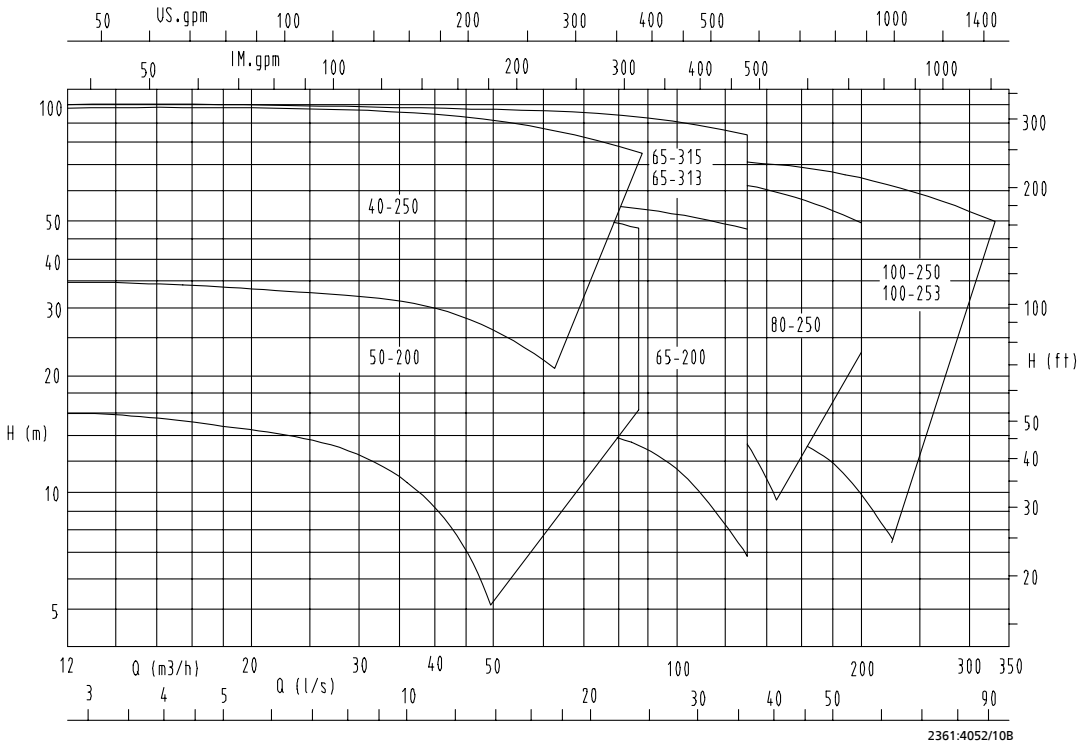

KWP, K impeller, n=1450 rpm

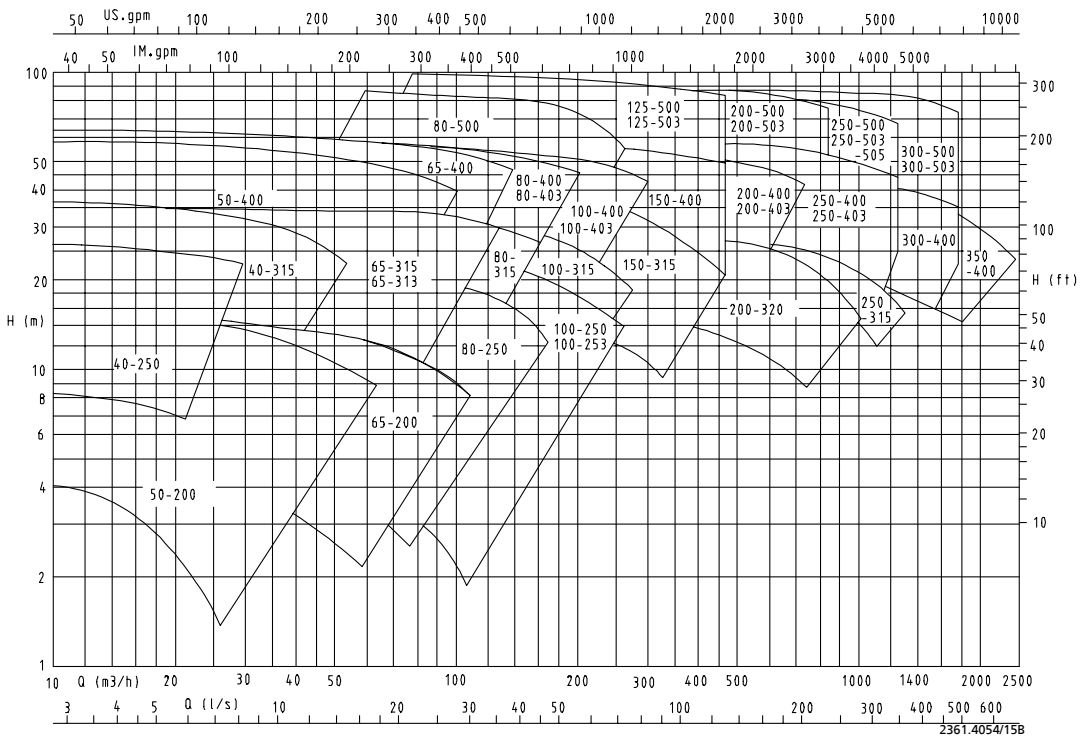

KWP, K impeller, n=480 rpm

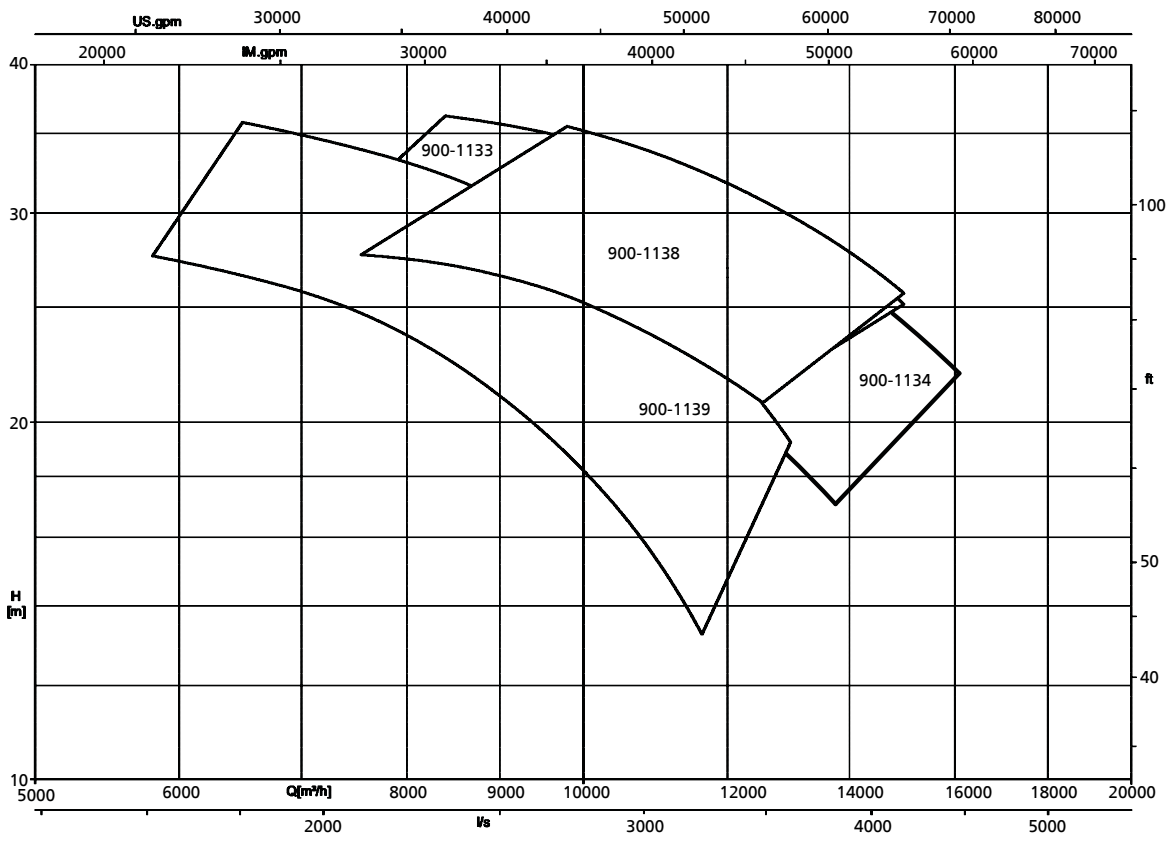

Dimensions and connections

Bearing brackets P03ax to P06x

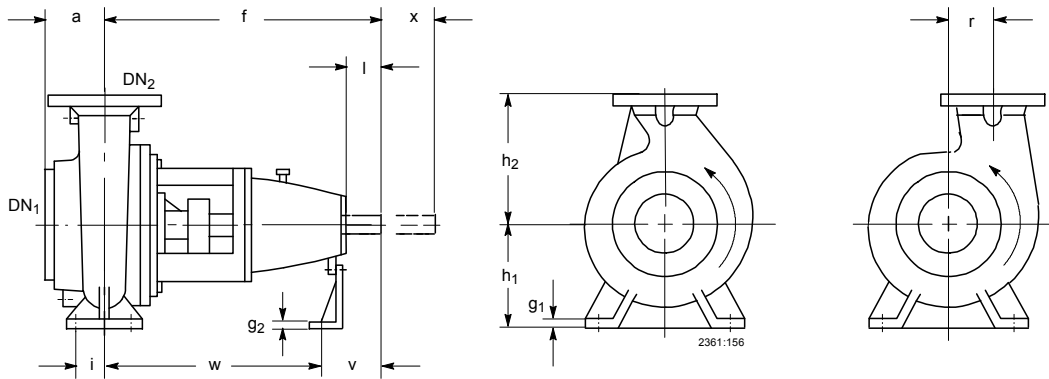

Pump dimensions (P03ax to P06x)

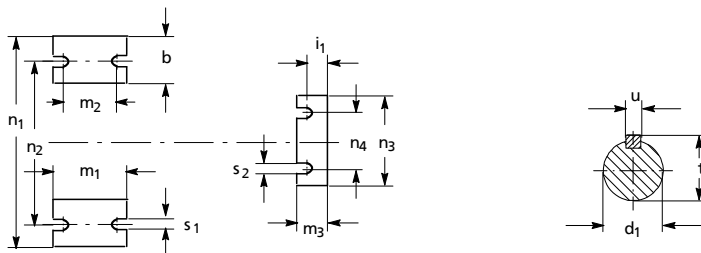

Dimensions of pump feet and shaft end (P03ax to P06x)

Pump dimensions (P03ax to P06x)

Size	Bearing bracket	DN ₁	DN ₂	a	b	f	g ₁	g ₂	h ₁	h ₂	r	m ₁	m ₃	n ₁	n ₃	x ¹⁰⁾
065-040-0250	P03ax	65	40	100	65	500	16	4	180	225	-	125	48	320	160	100
065-050-0200	P03ax	65	50	112	50	500	14	4	160	200	-	100	48	265	160	100
065-050-0201	P03ax	65	50	112	50	500	14	4	160	200	-	100	48	265	160	100
080-040-0315	P04ax	80	40	125	80	530	18	6	225	250	-	160	48	400	160	140
080-050-0400	P04ax	80	50	120	80	530	18	6	280	325	-	160	48	435	160	140
080-065-0200	P03ax	80	65	125	65	500	16	4	180	225	-	125	48	320	160	100
080-065-0201	P03ax	80	65	125	65	500	16	4	180	225	-	125	48	320	160	100
080-065-0311	P04ax	80	65	140	80	530	18	6	225	280	-	160	48	400	160	120
080-065-0313	P04ax	80	65	140	80	530	18	6	225	280	-	160	48	400	160	120
080-065-0315	P04ax	80	65	140	80	530	18	6	225	280	-	160	48	400	160	120
080-065-0400	P04ax	80	65	140	80	530	18	6	280	355	-	160	48	435	160	120
100-080-0250	P03ax	100	80	125	80	500	18	6	225	280	-	160	48	400	160	120
100-080-0251	P03ax	100	80	125	80	500	18	6	225	280	-	160	48	400	160	120
100-080-0311	P04ax	100	80	140	80	530	18	6	225	280	-	160	48	400	160	120
100-080-0315	P04ax	100	80	140	80	530	18	6	225	280	-	160	48	400	160	120
100-080-0400	P05ax	100	80	140	80	670	18	12	280	355	-	160	60	435	200	120
100-080-0403	P05ax	100	80	140	80	670	18	12	280	355	-	160	60	435	200	120
125-080-0500	P06x	125	80	140	100	720	24	12	355	450	-	200	60	550	200	160
125-100-0250	P04ax	125	100	140	80	530	18	6	225	280	-	160	48	400	160	140
125-100-0251	P04ax	125	100	140	80	530	18	6	225	280	-	160	48	400	160	140
125-100-0253	P04ax	125	100	140	80	530	18	6	225	280	-	160	48	400	160	140
125-100-0315	P04ax	125	100	140	80	530	18	6	250	315	-	180	48	400	160	140
125-100-0400	P05ax	125	100	140	100	670	20	12	280	355	-	200	60	500	200	160

¹⁰⁾ x = back pull-out clearance (without removing the motor)

Size	Bearing bracket	DN ₁	DN ₂	a	b	f	g ₁	g ₂	h ₁	h ₂	r	m ₁	m ₃	n ₁	n ₃	x ¹⁰⁾
125-100-0403	P05ax	125	100	140	100	670	20	12	280	355	-	200	60	500	200	160
150-125-0500	P06x	150	125	160	100	720	24	12	355	450	-	200	60	550	200	160
150-125-0503	P06x	150	125	160	100	720	24	12	355	450	-	200	60	550	200	160
150-150-0311	P05ax	150	150	180	100	670	22	12	315	400	-	200	60	550	200	160
150-150-0315	P05ax	150	150	180	100	670	22	12	315	400	-	200	60	550	200	160
150-150-0400	P05ax	150	150	160	100	670	22	12	315	450	-	200	60	550	200	160
150-150-0403	P05ax	150	150	160	100	670	22	12	315	450	-	200	60	550	200	160
200-200-0320	P05ax	200	200	200	100	697	22	12	355	450	-	200	60	550	200	160
200-200-0400	P06x	200	200	180	100	720	24	12	355	500	-	200	60	550	200	160
200-200-0403	P06x	200	200	180	100	720	24	12	355	500	-	200	60	550	200	160
250-250-0315	P06x	250	250	215	130	720	26	12	500	400	315	260	60	800	200	160

Dimensions of shaft end and pump feet (P03ax to P06x)

Bearing bracket	Size	Shaft end				Pump feet									
		d ₁	l	t	u	i	i ₁	m ₂	n ₂	n ₄	s ₁	s ₂	v	w	
P03ax	065-040-0250	32	80	35,3	10	47,5	30	95	250	110	16	14	130	370	
P03ax	065-050-0200	32	80	35,3	10	35	30	70	212	110	14	14	130	370	
P03ax	065-050-0201	32	80	35,3	10	35	30	70	212	110	14	14	130	370	
P03ax	080-065-0200	32	80	35,3	10	47,5	30	95	250	110	14	14	130	370	
P03ax	080-065-0201	32	80	35,3	10	47,5	30	95	250	110	14	14	130	370	
P03ax	100-080-0250	32	80	35,3	10	60	30	120	315	110	18	14	130	370	
P03ax	100-080-0251	32	80	35,3	10	60	30	120	315	110	18	14	130	370	
P04ax	080-040-0315	42	110	45,1	12	60	33	120	315	110	18	14	160	370	
P04ax	080-050-0400	42	110	45,1	12	60	33	120	355	110	19	14	160	370	
P04ax	080-065-0311	42	110	45,1	12	60	33	120	315	110	18	14	160	370	
P04ax	080-065-0313	42	110	45,1	12	60	33	120	315	110	18	14	160	370	
P04ax	080-065-0315	42	110	45,1	12	60	33	120	315	110	18	14	160	370	
P04ax	080-065-0400	42	110	45,1	12	60	33	120	355	110	19	14	160	370	
P04ax	100-080-0311	42	110	45,1	12	60	33	120	315	110	19	14	160	370	
P04ax	100-080-0315	42	110	45,1	12	60	33	120	315	110	19	14	160	370	
P04ax	125-100-0250	42	110	45,1	12	60	33	120	315	110	18	14	160	370	
P04ax	125-100-0251	42	110	45,1	12	60	33	120	315	110	18	14	160	370	
P04ax	125-100-0253	42	110	45,1	12	60	33	120	315	110	18	14	160	370	
P04ax	125-100-0315	42	110	45,1	12	60	33	120	315	110	18	14	160	370	
P05ax	100-080-0400	48	110	51,5	14	60	39	120	355	140	18	18	170	500	
P05ax	100-080-0403	48	110	51,5	14	60	39	120	355	140	18	18	170	500	
P05ax	125-100-0400	48	110	51,5	14	75	39	150	400	140	23	18	170	500	
P05ax	125-100-0403	48	110	51,5	14	75	39	150	400	140	23	18	170	500	
P05ax	150-150-0311	48	110	51,5	14	75	39	150	450	140	23	18	170	500	
P05ax	150-150-0315	48	110	51,5	14	75	39	150	450	140	23	18	170	500	
P05ax	150-150-0400	48	110	51,5	14	75	39	150	450	140	23	18	170	500	
P05ax	150-150-0403	48	110	51,5	14	75	39	150	450	140	23	18	170	500	
P05ax	200-200-0320	48	110	51,5	14	75	39	150	450	140	22	18	170	527	
P06x	125-080-0500	60	140	64,2	18	75	39	150	450	140	23	18	205	515	
P06x	150-125-0500	60	140	64,2	18	75	39	150	450	140	23	18	205	515	
P06x	150-125-0503	60	140	64,2	18	75	39	150	450	140	23	18	205	515	
P06x	200-200-0400	60	140	64,2	18	75	39	150	450	140	23	18	205	515	
P06x	200-200-0403	60	140	64,2	18	75	39	150	450	140	23	18	205	515	
P06x	250-250-0315	60	140	64,2	18	95	39	190	670	140	26	18	205	515	

¹⁰⁾ x = back pull-out clearance (without removing the motor)

Bearing brackets P08sx to P12sx

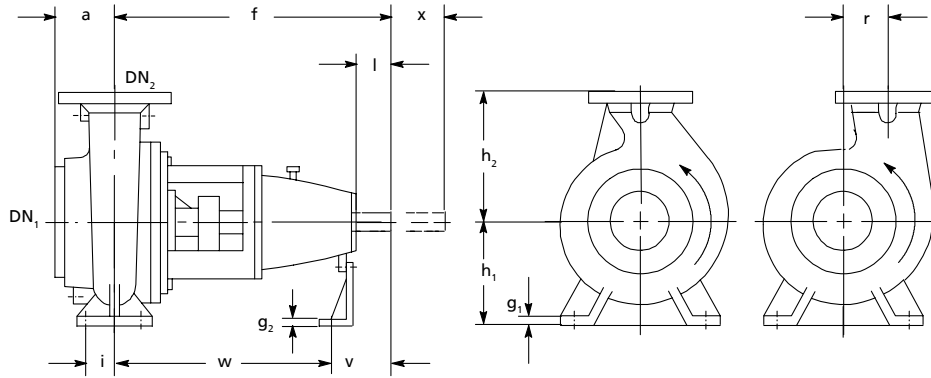

Pump dimensions (P08sx to P12sx)

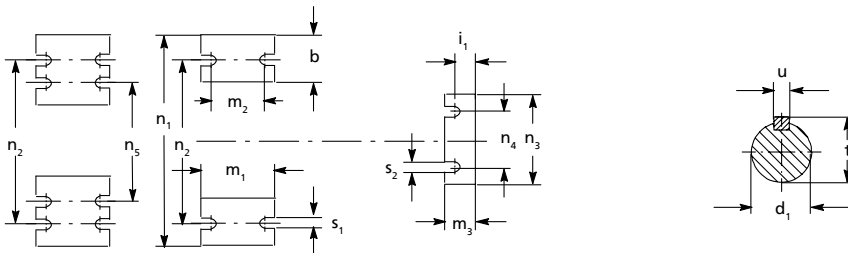

Dimensions of pump feet and shaft end (P08sx to P12sx)

Pump dimensions (P08sx to P12sx)

Size	Bearing bracket	DN ₁	DN ₂	a	b	g ₁	g ₂	h ₁	h ₂	r	m ₁	m ₃	n ₁	n ₃	x ¹¹⁾
200-200-0500	P08sx/P10ax/P12sx	200	200	200	120	24	12	375	560	-	200	60	700	200	250
200-200-0501	P08sx/P10ax/P12sx	200	200	200	120	24	12	375	560	-	200	60	700	200	250
200-200-0503	P08sx/P10ax/P12sx	200	200	200	120	24	12	375	560	-	200	60	700	200	250
250-250-0400	P08sx/P10ax	250	250	180	130	26	12	425	375	300	260	60	800	200	315
250-250-0403	P08sx/P10ax	250	250	180	130	26	12	425	375	300	260	60	800	200	315
250-250-0500	P08sx/P10ax/P12sx	250	250	200	130	26	12	425	400	315	260	60	800	200	315
250-250-0503	P08sx/P10ax/P12sx	250	250	200	130	26	12	425	400	315	260	60	800	200	315
250-250-0505	P08sx/P10ax/P12sx	250	250	200	130	26	12	425	400	315	260	60	800	200	315
250-250-0630	P08sx/P10ax/P12sx	250	250	200	150	32	12	500	450	400	260	60	900	200	315
250-250-0634	P08sx/P10ax/P12sx	250	250	200	150	32	12	500	450	400	260	60	900	200	315
300-300-0400	P08sx/P10ax	300	300	180	180	32	12	500	400	390	360	60	900	200	315
300-300-0500	P08sx/P10ax/P12sx	300	300	200	130	26	12	450	450	315	260	60	800	200	315
300-300-0503	P08sx/P10ax/P12sx	300	300	200	130	26	12	450	450	315	260	60	800	200	315
350-350-0400	P08sx/P10ax	350	350	200	225	32	12	560	450	395	400	60	1080	200	315
350-350-0500 ¹²⁾	P08sx/P10ax/P12sx	350	350	290	225	32	12	560	500	415	400	60	1080	200	315
350-350-0503 ¹²⁾	P08sx/P10ax/P12sx	350	350	290	225	32	12	560	500	415	400	60	1080	200	315
350-350-0504 ¹²⁾	P08sx/P10ax/P12sx	350	350	290	225	32	12	560	500	415	400	60	1080	200	315
350-350-0630	P08sx/P10ax/P12sx	350	350	250	150	32	12	560	560	400	360	60	900	200	350
350-350-0633	P08sx/P10ax/P12sx	350	350	250	150	32	12	560	560	400	360	60	900	200	350
400-400-0500	P08sx/P10ax/P12sx	400	400	260	250	40	16	670	500	490	400	85	1150	216	400
400-400-0503	P08sx/P10ax/P12sx	400	400	260	250	40	16	670	500	490	400	85	1150	216	400
400-400-0533 ¹²⁾	P10ax/P12sx	400	400	350	250	40	16	630	525	475	360	70	1150	200	400
400-400-0583 ¹²⁾	P10ax/P12sx	400	400	390	250	40	16	700	540	510	400	110	1150	216	400
500-400-0710 ¹²⁾	P10ax/P12sx	500	400	350	250	40	16	670	600	480	400	65	1150	216	350

11) x = back pull-out clearance (without removing the motor)

12) No block flange but standard flange with through-holes

	Size	Bearing bracket	DN ₁	DN ₂	a	b	g ₁	g ₂	h ₁	h ₂	r	m ₁	m ₃	n ₁	n ₃	x ¹¹⁾
500-400-0713 ¹²⁾	P10ax/P12sx		500	400	350	250	40	16	670	600	480	400	65	1150	216	350
500-500-0544 ¹²⁾	P10ax/P12sx		500	500	425	250	40	30	800	630	585	400	90	1400	600	450
500-500-0630 ¹²⁾	P10ax/P12sx		500	500	375	250	40	16	750	630	575	400	100	1400	216	400
500-500-0633 ¹²⁾	P10ax/P12sx		500	500	375	250	40	16	750	630	575	400	100	1400	216	400
500-500-0634 ¹²⁾	P10ax/P12sx		500	500	375	250	40	16	750	630	575	400	100	1400	216	400
500-500-0635 ¹²⁾	P10ax/P12sx		500	500	375	250	40	16	750	630	575	400	100	1400	216	400
500-500-0637 ¹²⁾	P10ax/P12sx		500	500	375	250	40	16	750	630	575	400	100	1400	216	400
600-600-0663 ¹²⁾	P12sx		600	600	400	250	40	16	800	630	615	400	125	1400	200	500
600-600-0669 ¹²⁾	P12sx		600	600	400	250	40	16	800	630	615	400	125	1400	200	500
600-600-0710 ¹²⁾	P12sx		600	600	500	250	40	18	900	750	680	400	70	1600	200	500

Dimensions of shaft end and pump feet (P08sx to P12sx)

Bearing bracket	Size	Shaft end [mm]				Pump feet [mm]										
		d ₁	l	t	u	i	i ₁	m ₂	n ₂	n ₄	n ₅	s ₁	s ₂	f	v	w
P08sx	200-200-0500	75	150	97,7	20	75	39	150	560	140	-	23	18	970	220	750
P08sx	200-200-0501	75	150	97,7	20	75	39	150	560	140	-	23	18	970	220	750
P08sx	200-200-0503	75	150	97,7	20	75	39	150	560	140	-	23	18	970	220	750
P08sx	250-250-0400	75	150	97,7	20	95	39	190	670	140	-	26	18	1000	220	780
P08sx	250-250-0403	75	150	97,7	20	95	39	190	670	140	-	26	18	1000	220	780
P08sx	250-250-0500	75	150	97,7	20	95	39	190	670	140	-	28	18	1000	220	780
P08sx	250-250-0503	75	150	97,7	20	95	39	190	670	140	-	28	18	1000	220	780
P08sx	250-250-0505	75	150	97,7	20	95	39	190	670	140	-	28	18	1000	220	780
P08sx	250-250-0630	75	150	97,7	20	95	39	190	750	140	-	26	18	1000	220	780
P08sx	250-250-0634	75	150	97,7	20	95	39	190	750	140	-	26	18	1000	220	780
P08sx	300-300-0400	75	150	97,7	20	125	39	250	750	140	-	28	18	1000	220	780
P08sx	300-300-0500	75	150	97,7	20	95	39	190	670	140	-	28	18	1000	220	780
P08sx	300-300-0503	75	150	97,7	20	95	39	190	670	140	-	28	18	1000	220	780
P08sx	350-350-0400	75	150	97,7	20	150	39	300	1000	140	750	28	18	1000	220	780
P08sx	350-350-0500	75	150	97,7	20	150	39	300	1000	140	750	28	18	1000	220	780
P08sx	350-350-0503	75	150	97,7	20	150	39	300	1000	140	750	28	18	1000	220	780
P08sx	350-350-0504	75	150	97,7	20	150	39	300	1000	140	750	28	18	1000	220	780
P08sx	350-350-0630	75	150	97,7	20	125	39	250	750	140	-	28	18	1000	220	780
P08sx	350-350-0633	75	150	97,7	20	125	39	250	750	140	-	28	18	1000	220	780
P08sx	400-400-0500	75	150	97,7	20	150	59	300	1040	140	800	39	18	1000	220	780
P08sx	400-400-0503	75	150	97,7	20	150	59	300	1040	140	800	39	18	1000	220	780
P10ax	200-200-0500	95	220	100,2	25	75	39	150	560	140	-	23	18	1160	410	750
P10ax	200-200-0501	95	220	100,2	25	75	39	150	560	140	-	23	18	1160	410	750
P10ax	200-200-0503	95	220	100,2	25	75	39	150	560	140	-	23	18	1160	410	750
P10ax	250-250-0400	95	220	100,2	25	95	39	190	670	140	-	26	18	1190	410	780
P10ax	250-250-0403	95	220	100,2	25	95	39	190	670	140	-	26	18	1190	410	780
P10ax	250-250-0500	95	220	100,2	25	95	39	190	670	140	-	28	18	1190	410	780
P10ax	250-250-0503	95	220	100,2	25	95	39	190	670	140	-	28	18	1190	410	780
P10ax	250-250-0505	95	220	100,2	25	95	39	190	670	140	-	28	18	1190	410	780
P10ax	250-250-0630	95	220	100,2	25	95	39	190	750	140	-	26	18	1190	410	780
P10ax	250-250-0634	95	220	100,2	25	95	39	190	750	140	-	26	18	1190	410	780
P10ax	300-300-0400	95	220	100,2	25	125	39	250	750	140	-	28	18	1190	410	780
P10ax	300-300-0500	95	220	100,2	25	95	39	190	670	140	-	28	18	1190	410	780
P10ax	300-300-0503	95	220	100,2	25	95	39	190	670	140	-	28	18	1190	410	780
P10ax	350-350-0400	95	220	100,2	25	150	39	300	1000	140	750	28	18	1190	410	780
P10ax	350-350-0500	95	220	100,2	25	150	39	300	1000	140	750	28	18	1190	410	780
P10ax	350-350-0503	95	220	100,2	25	150	39	300	1000	140	750	28	18	1190	410	780

11) x = back pull-out clearance (without removing the motor)

Bearing bracket	Size	Shaft end [mm]				Pump feet [mm]										
		d ₁	l	t	u	i	i ₁	m ₂	n ₂	n ₄	n ₅	s ₁	s ₂	f	v	w
P10ax	350-350-0504	95	220	100,2	25	150	39	300	1000	140	750	28	18	1190	410	780
P10ax	350-350-0630	95	220	100,2	25	125	39	250	750	140	-	28	18	1190	410	780
P10ax	350-350-0633	95	220	100,2	25	125	39	250	750	140	-	28	18	1190	410	780
P10ax	400-400-0500	95	220	100,2	25	150	59	300	1040	140	800	39	18	1190	410	790
P10ax	400-400-0503	95	220	100,2	25	150	59	300	1040	140	800	39	18	1190	410	790
P10ax	400-400-0533	95	220	100,2	25	125	50	250	1040	140	800	40	18	1175	450	725
P10ax	400-400-0583	95	220	100,2	25	150	50	300	1040	140	800	40	18	1180	450	730
P10ax	500-400-0710	95	220	100,2	25	150	59	300	1040	140	800	38	18	1205	425	780
P10ax	500-400-0713	95	220	100,2	25	150	59	300	1040	140	800	38	18	1205	425	780
P10ax	500-500-0544	95	220	100,2	25	150	60	300	1290	520	1050	38	18	1190	435	755
P10ax	500-500-0630	95	220	100,2	25	150	50	300	1290	140	1050	38	18	1190	410	780
P10ax	500-500-0633	95	220	100,2	25	150	50	300	1290	140	1050	38	18	1190	410	780
P10ax	500-500-0634	95	220	100,2	25	150	50	300	1290	140	1050	38	18	1190	410	780
P10ax	500-500-0635	95	220	100,2	25	150	50	300	1290	140	1050	38	18	1190	410	780
P10ax	500-500-0637	95	220	100,2	25	150	50	300	1290	140	1050	38	18	1190	410	780
P12sx	200-200-0500	110	220	116,2	28	75	39	150	560	140	-	23	18	1160	410	750
P12sx	200-200-0501	110	220	116,2	28	75	39	150	560	140	-	23	18	1160	410	750
P12sx	200-200-0503	110	220	116,2	28	75	39	150	560	140	-	23	18	1160	410	750
P12sx	250-250-0500	110	220	116,2	28	95	39	190	670	140	-	28	18	1190	410	780
P12sx	250-250-0503	110	220	116,2	28	95	39	190	670	140	-	28	18	1190	410	780
P12sx	250-250-0505	110	220	116,2	28	95	39	190	670	140	-	28	18	1190	410	780
P12sx	250-250-0630	110	220	116,2	28	95	39	190	750	140	-	26	18	1190	410	780
P12sx	250-250-0634	110	220	116,2	28	95	39	190	750	140	-	26	18	1190	410	780
P12sx	300-300-0500	110	220	116,2	28	95	39	190	670	140	-	28	18	1190	410	780
P12sx	300-300-0503	110	220	116,2	28	95	39	190	670	140	-	28	18	1190	410	780
P12sx	350-350-0500	110	220	116,2	28	150	39	300	1000	140	750	28	18	1190	410	780
P12sx	350-350-0503	110	220	116,2	28	150	39	300	1000	140	140	28	18	1190	410	780
P12sx	350-350-0504	110	220	116,2	28	150	39	300	1000	140	140	28	18	1190	410	780
P12sx	350-350-0630	110	220	116,2	28	125	39	250	750	140	-	28	18	1190	410	780
P12sx	350-350-0633	110	220	116,2	28	125	39	250	750	140	-	28	18	1190	410	780
P12sx	400-400-0500	110	220	116,2	28	150	59	300	1040	140	800	39	18	1190	410	790
P12sx	400-400-0503	110	220	116,2	28	150	59	300	1040	140	800	39	18	1190	410	790
P12sx	400-400-0533	110	220	116,2	28	125	50	250	1040	140	800	40	18	1175	450	725
P12sx	400-400-0583	110	220	116,2	28	150	50	300	1040	140	800	40	18	1180	450	730
P12sx	500-400-0710	110	220	116,2	28	150	59	300	1040	140	800	38	18	1205	425	780
P12sx	500-400-0713	110	220	116,2	28	150	59	300	1040	140	800	38	18	1205	425	780
P12sx	500-500-0544	110	220	116,2	28	150	60	300	1290	520	1050	38	18	1190	435	755
P12sx	500-500-0630	110	220	116,2	28	150	50	300	1290	140	1050	38	18	1190	410	780
P12sx	500-500-0633	110	220	116,2	28	150	50	300	1290	140	1050	38	18	1190	410	780
P12sx	500-500-0634	110	220	116,2	28	150	50	300	1290	140	1050	38	18	1190	410	780
P12sx	500-500-0635	110	220	116,2	28	150	50	300	1290	140	1050	38	18	1190	410	780
P12sx	500-500-0637	110	220	116,2	28	150	50	300	1290	140	1050	38	18	1190	410	780
P12sx	600-600-0663	110	220	116,2	28	150	60	300	1310	140	1150	39	18	1238	457	781
P12sx	600-600-0669	110	220	116,2	28	150	60	300	1310	140	1150	39	18	1238	457	781
P12sx	600-600-0710	110	220	116,2	28	150	55	300	1490	140	1250	38	18	1240	450	790

Bearing brackets P16ax and P20sx

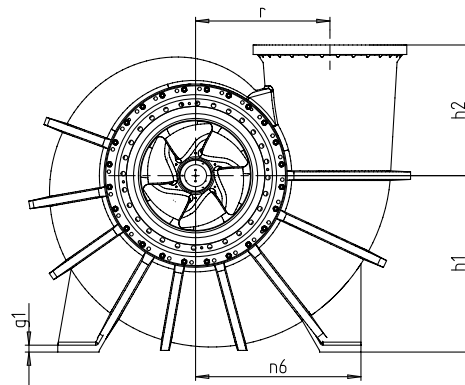
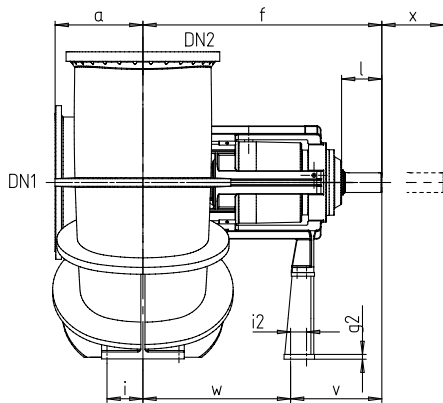

Pump dimensions (P16ax and P20sx)

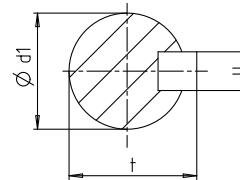
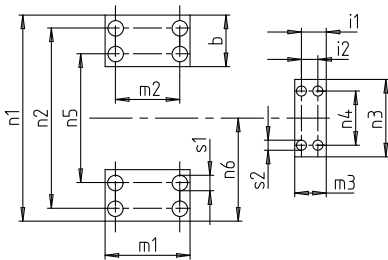

Dimensions of pump feet and shaft end (P16ax and P20sx)

Pump dimensions (P16ax and P20sx)

Size	Version	Bearing bracket	DN ₁	DN ₂	a	b	f	g ₁	g ₂	h ₁	h ₂	r	m ₁	m ₃	n ₁	n ₃	x ¹³⁾
500-400-0710	10	P16ax	500	400	350	250	1306	40	16	670	600	480	400	180	1150	216	350
500-400-0713	10	P16ax	500	400	350	250	1306	40	16	670	600	480	400	180	1150	216	350
500-500-0630	10	P16ax	500	500	375	250	1190	40	¹⁴⁾	750	630	575	400	¹⁴⁾	1400	¹⁴⁾	400
500-500-0633	10	P16ax	500	500	375	250	1190	40	¹⁴⁾	750	630	575	400	¹⁴⁾	1400	¹⁴⁾	400
500-500-0634	10	P16ax	500	500	375	250	1190	40	¹⁴⁾	750	630	575	400	¹⁴⁾	1400	¹⁴⁾	400
500-500-0635	10	P16ax	500	500	375	250	1190	40	¹⁴⁾	750	630	575	400	¹⁴⁾	1400	¹⁴⁾	400
500-500-0637	10	P16ax	500	500	375	250	1190	40	¹⁴⁾	750	630	575	400	¹⁴⁾	1400	¹⁴⁾	400
600-600-0710	10	P16ax	600	600	500	250	¹⁴⁾	40	¹⁴⁾	900	750	680	400	¹⁴⁾	1600	¹⁴⁾	500
600-600-0753	10	P16ax	600	600	450	240	1296	40	25	900	680	690	400	180	1600	350	450
600-600-0803	10	P16sx	600	600	450	250	1318	40	25	880	800	675	400	180	1600	350	460
600-600-0813	10	P16sx	600	600	500	250	1296	40	25	900	900	730	400	180	1560	350	450
600-600-0824	10	P16ax	600	600	445	250	1363	40	25	950	750	715	400	180	1560	350	500
600-600-0825	10	P16ax	600	600	445	250	1363	40	25	950	750	715	400	180	1560	350	500
600-600-0873	10	P16ax	600	600	470	240	1300	40	25	970	770	700	400	180	1650	350	470
600-600-0923	10	P20sx	600	600	500	250	1642	40	25	900	840	730	400	210	1560	450	450
700-700-0923	11	P20sx	700	700	490	250	1724	40	25	1050	690	770	500	210	1670	450	560
700-700-0929	11	P20sx	700	700	490	250	1724	40	25	1050	690	770	500	210	1670	450	560
800-700-0953	11	P20sx	800	700	550	210	1691,5	50	25	1100	720	770	500	210	1740	450	590
800-700-0959	11	P20sx	800	700	550	210	1691,5	50	25	1100	720	770	500	210	1740	450	590

¹³⁾ x = back pull-out clearance (without removing the motor)

¹⁴⁾ Dimensions on request

	Size	Version	Bearing bracket	DN ₁	DN ₂	a	b	f	g ₁	g ₂	h ₁	h ₂	r	m ₁	m ₃	n ₁	n ₃	x ¹³⁾
800-900-0883	10	P20sx		800	900	622	300	1784	50	25	1250	950	925	600	210	2250	450	660
800-800-0934	11	P20sx		800	800	500	240	1711,5	50	25	1080	760	832	500	210	1840	450	610
800-800-0939	11	P20sx		800	800	500	240	1711,5	50	25	1080	760	832	500	210	1840	450	610
900-900-1133	11	P20sx		900	900	492	300	1732,5	50	25	1280	950	975	600	210	2200	450	695
900-900-1134	11	P20sx		900	900	492	300	1732,5	50	25	1280	950	975	600	210	2200	450	695
900-900-1138	11	P20sx		900	900	492	300	1732,5	50	25	1280	950	975	600	210	2200	450	695
900-900-1139	11	P20sx		900	900	492	300	1732,5	50	25	1280	950	975	600	210	2200	450	695

Dimensions of shaft end and pump feet (P16ax to P20sx)

Bearing bracket	Size	Version	Shaft end [mm]				Pump feet [mm]											
			d ₁	l	t	u	i	i ₁	i ₂	m ₂	n ₂	n ₄	n ₅	n ₆	s ₁	s ₂	v	w
P16ax	500-400-0710	10	120	210	127,2	32	150	130	85	300	1040	250	800	575	38	18	476	830
P16ax	500-400-0713	10	120	210	127,2	32	150	130	85	300	1040	250	800	575	38	18	476	830
P16ax	500-500-0630	10	120	210	127,2	32	150	¹⁴⁾	¹⁴⁾	300	1290	¹⁴⁾	1050	700	38	¹⁴⁾	¹⁴⁾	¹⁴⁾
P16ax	500-500-0633	10	120	210	127,2	32	150	¹⁴⁾	¹⁴⁾	300	1290	¹⁴⁾	1050	700	38	¹⁴⁾	¹⁴⁾	¹⁴⁾
P16ax	500-500-0634	10	120	210	127,2	32	150	¹⁴⁾	¹⁴⁾	300	1290	¹⁴⁾	1050	700	38	¹⁴⁾	¹⁴⁾	¹⁴⁾
P16ax	500-500-0635	10	120	210	127,2	32	150	¹⁴⁾	¹⁴⁾	300	1290	¹⁴⁾	1050	700	38	¹⁴⁾	¹⁴⁾	¹⁴⁾
P16ax	500-500-0637	10	120	210	127,2	32	150	¹⁴⁾	¹⁴⁾	300	1290	¹⁴⁾	1050	700	38	¹⁴⁾	¹⁴⁾	¹⁴⁾
P16ax	600-600-0710	10	120	210	127,2	32	150	¹⁴⁾	¹⁴⁾	300	1490	¹⁴⁾	1250	800	38	¹⁴⁾	¹⁴⁾	¹⁴⁾
P16ax	600-600-0753	10	120	210	127,2	32	150	130	85	300	1490	250	1250	800	39	17,5	476	820
P16ax	600-600-0803	10	120	210	127,2	32	150	130	85	300	1490	250	1250	800	40	18	476	842
P16ax	600-600-0813	10	120	210	127,2	32	150	130	85	300	1450	250	1250	780	39	17,5	476	820
P16ax	600-600-0824	10	120	210	127,2	32	150	130	85	300	1450	250	1250	800	39	18	476	887
P16ax	600-600-0825	10	120	210	127,2	32	150	130	85	300	1450	250	1250	800	39	18	476	887
P16ax	600-600-0873	10	120	210	127,2	32	150	130	85	300	1540	250	1300	825	39	18	476	824
P20sx	600-600-0923	10	145	270	153	36	150	165	110	300	1450	350	1250	800	39	17,5	658,5	983,5
P20sx	700-700-0923	11	145	270	153	36	200	165	110	400	1550	350	1330	850	39	17,5	658,5	1065,5
P20sx	700-700-0929	11	145	270	153	36	200	165	110	400	1550	350	1330	850	39	17,5	658,5	1065,5
P20sx	800-700-0953	11	145	270	153	36	200	165	110	400	1640	350	1460	870	39	17,5	658,5	1033,5
P20sx	800-700-0959	11	145	270	153	36	200	165	110	400	1640	350	1460	870	39	17,5	658,5	1033,5
P20sx	800-800-0934	11	145	270	153	36	200	165	110	400	1740	350	1500	920	39	17,5	658,5	1053
P20sx	800-800-0939	11	145	270	153	36	200	165	110	400	1740	350	1500	920	39	17,5	658,5	1053
P20sx	800-900-0883	10	145	270	153	36	200	165	110	400	2140	350	1860	1270	39	17,5	658,5	1125
P20sx	900-900-1133	11	145	270	153	36	250	165	110	500	2040	350	1800	1200	39	17,5	658,5	1075
P20sx	900-900-1134	11	145	270	153	36	250	165	110	500	2040	350	1800	1200	39	17,5	658,5	1075
P20sx	900-900-1138	11	145	270	153	36	250	165	110	500	2040	350	1800	1200	39	17,5	658,5	1075
P20sx	900-900-1139	11	145	270	153	36	250	165	110	500	2040	350	1800	1200	39	17,5	658,5	1075

¹³⁾ x = back pull-out clearance (without removing the motor)

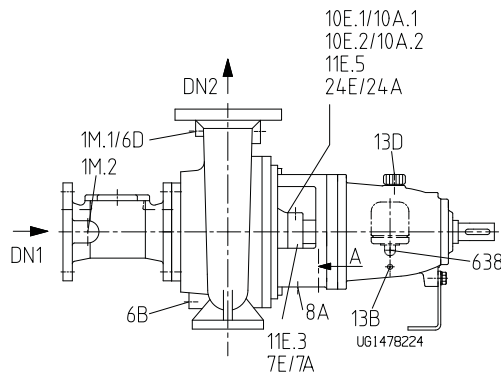
Connections

Pump connections

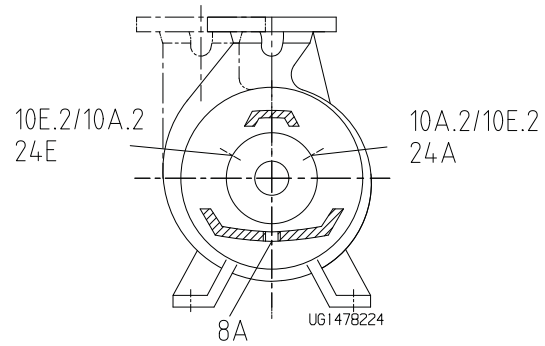

Mechanical seal connections

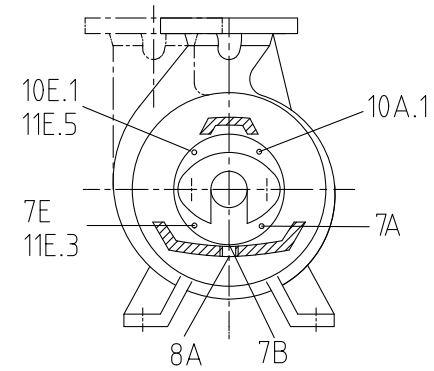

Gland packing connections

Designation	Use	Designation	Use
1M.1/2	Pressure gauge	10E.1/A.1	Barrier fluid inlet/outlet (gland packing)
6B	Casing drain	10E.2	Barrier fluid inlet (mechanical seal), discharge cover
6D	Venting	10A.2	Barrier fluid outlet (mechanical seal), seal cover
7E/A	Cooling liquid IN/OUT	10E.2/A.2	Barrier fluid inlet/outlet (mechanical seal), seal cover
7B	Cooling chamber drain	10E.2/A.2	Barrier fluid inlet/outlet (mechanical seal) ¹⁵⁾
8A	Leakage drain	13B	Oil drain
11E.3	Gap flush, outboard (stuffing box housing)	13D	Vent plug
11E.5	Flushing liquid inlet (gland packing)	24E/A	Quench liquid IN/OUT, seal cover ¹⁶⁾
638	Constant level oiler	24E/A	Quench liquid IN/OUT, seal cover (mechanical seal 4K)

15) Mechanical seal type Cartex DN P03ax to P10ax

16) Mechanical seal type TA (MG1-G6/M3 - HRZ/M3 - 587SP-D/M3)

Connections

Size	1M.1	1M.2	6B	6D	7E/A	7B	8A		10E.1/A.1	10E.2 (mechanical seal), discharge cover	10A.2 (mechanical seal), seal cover	10E.2/A.2 (mechanical seal), seal cover	10E.2/A.2 (mechanical seal) ¹⁷⁾	11E.3	11E.5	13B	13D	24E/A, seal cover ¹⁸⁾ 24E/A	(mechanical seal type 4K), seal cover	638
065-040-250	G 1/2	G 1/2	G 3/4	G 1/2	G 1/4	G 1/8	R 1/2	G 1/4	G 1/4	G 1/4	G 1/4	G 1/4	NPT 3/8	G 1/4	G 1/4	G 1/4	Ø 20	G 1/4	G 1/4	R 1/4
065-050-200	G 1/2	G 1/2	G 3/4	G 1/2	G 1/4	G 1/8	R 1/2	G 1/4	G 1/4	G 1/4	G 1/4	G 1/4	NPT 3/8	G 1/4	G 1/4	G 1/4	Ø 20	G 1/4	G 1/4	R 1/4
065-050-201	G 1/2	G 1/2	G 3/4	G 1/2	G 1/4	G 1/8	R 1/2	G 1/4	G 1/4	G 1/4	G 1/4	G 1/4	NPT 3/8	G 1/4	G 1/4	G 1/4	Ø 20	G 1/4	G 1/4	R 1/4
080-065-200	G 1/2	G 1/2	G 3/4	G 1/2	G 1/4	G 1/8	R 1/2	G 1/4	G 1/4	G 1/4	G 1/4	G 1/4	NPT 3/8	G 1/4	G 1/4	G 1/4	Ø 20	G 1/4	G 1/4	R 1/4
080-065-201	G 1/2	G 1/2	G 3/4	G 1/2	G 1/4	G 1/8	R 1/2	G 1/4	G 1/4	G 1/4	G 1/4	G 1/4	NPT 3/8	G 1/4	G 1/4	G 1/4	Ø 20	G 1/4	G 1/4	R 1/4
080-065-313	G 1/2	G 1/2	G 3/4	G 1/2	G 1/4	G 1/8	R 1/2	G 1/4	G 1/4	G 1/4	G 1/4	G 1/4	NPT 3/8	G 1/4	G 1/4	G 1/4	Ø 20	G 1/4	G 1/4	R 1/4
080-040-315	G 1/2	G 1/2	G 3/4	G 1/2	G 1/4	G 1/8	R 1/2	G 1/4	G 1/4	G 1/4	G 1/4	G 1/4	NPT 3/8	G 1/4	G 1/4	G 1/4	Ø 20	G 1/4	G 1/4	R 1/4
080-050-400	G 1/2	G 1/2	G 1	G 1/2	G 1/4	G 1/8	R 1/2	G 1/4	G 1/4	G 1/4	G 1/4	G 1/4	NPT 3/8	G 1/4	G 1/4	G 1/4	Ø 20	G 1/4	G 1/4	R 1/4
080-065-315	G 1/2	G 1/2	G 3/4	G 1/2	G 1/4	G 1/8	R 1/2	G 1/4	G 1/4	G 1/4	G 1/4	G 1/4	NPT 3/8	G 1/4	G 1/4	G 1/4	Ø 20	G 1/4	G 1/4	R 1/4
080-065-400	G 1	G 1/2	G 1	G 1	G 1/4	G 1/8	R 1/2	G 1/4	G 1/4	G 1/4	G 1/4	G 1/4	NPT 3/8	G 1/4	G 1/4	G 1/4	Ø 20	G 1/4	G 1/4	R 1/4
100-080-250	G 1	G 1/2	G 3/4	G 1	G 1/4	G 1/8	R 1/2	G 1/4	G 1/4	G 1/4	G 1/4	G 1/4	NPT 3/8	G 1/4	G 1/4	G 1/4	Ø 20	G 1/4	G 1/4	R 1/4
100-080-251	G 1	G 1/2	G 3/4	G 1	G 1/4	G 1/8	R 1/2	G 1/4	G 1/4	G 1/4	G 1/4	G 1/4	NPT 3/8	G 1/4	G 1/4	G 1/4	Ø 20	G 1/4	G 1/4	R 1/4
100-080-311	G 1	G 1/2	G 3/4	G 1	G 1/4	G 1/8	R 1/2	G 1/4	G 1/4	G 1/4	G 1/4	G 1/4	NPT 3/8	G 1/4	G 1/4	G 1/4	Ø 20	G 1/4	G 1/4	R 1/4
100-080-315	G 1	G 1/2	G 3/4	G 1	G 1/4	G 1/8	R 1/2	G 1/4	G 1/4	G 1/4	G 1/4	G 1/4	NPT 3/8	G 1/4	G 1/4	G 1/4	Ø 20	G 1/4	G 1/4	R 1/4
100-080-400	G 1	G 1/2	G 1	G 1	G 3/8	G 1/8	R 1/2	G 3/8	G 3/8	G 1/4	G 1/4	G 1/4	NPT 3/8	G 3/8	G 3/8	G 1/4	Ø 20	G 1/4	G 1/4	R 1/4
100-080-403	G 1	G 1/2	G 1	G 1	G 3/8	G 1/8	R 1/2	G 3/8	G 3/8	G 1/4	G 1/4	G 1/4	NPT 3/8	G 3/8	G 3/8	G 1/4	Ø 20	G 1/4	G 1/4	R 1/4
125-080-500	G 1	G 1/2	G 1	G 1	G 3/8	G 1/8	R 1/2	G 3/8	G 3/8	G 1/4	G 1/4	G 1/4	NPT 3/8	G 3/8	G 3/8	G 1/4	Ø 20	G 1/4	G 1/4	R 1/4
125-100-250	G 1	G 1/2	G 1	G 1	G 1/4	G 1/8	R 1/2	G 1/4	G 1/4	G 1/4	G 1/4	G 1/4	NPT 3/8	G 1/4	G 1/4	G 1/4	Ø 20	G 1/4	G 1/4	R 1/4
125-100-251	G 1	G 1/2	G 1	G 1	G 1/4	G 1/8	R 1/2	G 1/4	G 1/4	G 1/4	G 1/4	G 1/4	NPT 3/8	G 1/4	G 1/4	G 1/4	Ø 20	G 1/4	G 1/4	R 1/4
125-100-253	G 1	G 1/2	G 1	G 1	G 1/4	G 1/8	R 1/2	G 1/4	G 1/4	G 1/4	G 1/4	G 1/4	NPT 3/8	G 1/4	G 1/4	G 1/4	Ø 20	G 1/4	G 1/4	R 1/4
125-100-315	G 1	G 1/2	G 1	G 1	G 1/4	G 1/8	R 1/2	G 1/4	G 1/4	G 1/4	G 1/4	G 1/4	NPT 3/8	G 1/4	G 1/4	G 1/4	Ø 20	G 1/4	G 1/4	R 1/4
125-100-400	G 1	G 1/2	G 1	G 1	G 3/8	G 1/8	R 1/2	G 3/8	G 3/8	G 1/4	G 1/4	G 1/4	NPT 3/8	G 3/8	G 3/8	G 1/4	Ø 20	G 1/4	G 1/4	R 1/4
125-100-403	G 1	G 1/2	G 1	G 1	G 3/8	G 1/8	R 1/2	G 3/8	G 3/8	G 1/4	G 1/4	G 1/4	NPT 3/8	G 3/8	G 3/8	G 1/4	Ø 20	G 1/4	G 1/4	R 1/4
150-150-311	G 1	G 1/2	G 1	G 1	G 3/8	G 1/8	R 1/2	G 3/8	G 3/8	G 1/4	G 1/4	G 1/4	NPT 3/8	G 3/8	G 3/8	G 1/4	Ø 20	G 1/4	G 1/4	R 1/4
150-150-315	G 1	G 1/2	G 1	G 1	G 3/8	G 1/8	R 1/2	G 3/8	G 3/8	G 1/4	G 1/4	G 1/4	NPT 3/8	G 3/8	G 3/8	G 1/4	Ø 20	G 1/4	G 1/4	R 1/4
150-150-400	G 1	G 1/2	G 1	G 1	G 3/8	G 1/8	R 1/2	G 3/8	G 3/8	G 1/4	G 1/4	G 1/4	NPT 3/8	G 3/8	G 3/8	G 1/4	Ø 20	G 1/4	G 1/4	R 1/4
150-150-403	G 1	G 1/2	G 1	G 1	G 3/8	G 1/8	R 1/2	G 3/8	G 3/8	G 1/4	G 1/4	G 1/4	NPT 3/8	G 3/8	G 3/8	G 1/4	Ø 20	G 1/4	G 1/4	R 1/4
150-125-500	G 1	G 1/2	G 1	G 1	G 3/8	G 1/8	R 1/2	G 3/8	G 3/8	G 1/4	G 1/4	G 1/4	NPT 3/8	G 3/8	G 3/8	G 1/4	Ø 20	G 1/4	G 1/4	R 1/4
150-125-503	G 1	G 1/2	G 1	G 1	G 3/8	G 1/8	R 1/2	G 3/8	G 3/8	G 1/4	G 1/4	G 1/4	NPT 3/8	G 3/8	G 3/8	G 1/4	Ø 20	G 1/4	G 1/4	R 1/4
200-200-320	G 1	G 1/2	G 1	G 1	G 3/8	G 1/8	R 1/2	G 3/8	G 3/8	G 1/4	G 1/4	G 1/4	NPT 3/8	G 3/8	G 3/8	G 1/4	Ø 20	G 1/4	G 1/4	R 1/4
200-200-400	G 1	G 1/2	G 1	G 1	G 3/8	G 1/8	R 1/2	G 3/8	G 3/8	G 1/4	G 1/4	G 1/4	NPT 3/8	G 3/8	G 3/8	G 1/4	Ø 20	G 1/4	G 1/4	R 1/4
200-200-403	G 1	G 1/2	G 1	G 1	G 3/8	G 1/8	R 1/2	G 3/8	G 3/8	G 1/4	G 1/4	G 1/4	NPT 3/8	G 3/8	G 3/8	G 1/4	Ø 20	G 1/4	G 1/4	R 1/4
200-200-500	G 1	G 1/2	G 1	G 1	G 3/8	G 1/4	R 1/2	G 3/8	-	-	G 1/2 ¹⁹⁾	NPT 3/8	G 3/8	G 3/8	G 1/2	Ø 20	G 1/2 ¹⁹⁾	G 1/4	R 1/4	
200-200-501	G 1	G 1/2	G 1	G 1	G 3/8	G 1/4	R 1/2	G 3/8	-	-	G 1/2 ¹⁹⁾	NPT 3/8	G 3/8	G 3/8	G 1/2	Ø 20	G 1/2 ¹⁹⁾	G 1/4	R 1/4	
200-200-503	G 1	G 1/2	G 1	G 1	G 3/8	G 1/4	R 1/2	G 3/8	-	-	G 1/2 ¹⁹⁾	NPT 3/8	G 3/8	G 3/8	G 1/2	Ø 20	G 1/2 ¹⁹⁾	G 1/4	R 1/4	
250-250-315	G 1/2	G 1/2	G 1	G 1	G 3/8	G 1/8	R 1/2	G 3/8	G 3/8	G 1/4	G 1/4	G 1/4	NPT 3/8	G 3/8	G 3/8	G 1/4	Ø 20	G 1/4	G 1/4	R 1/4
250-250-400	G 1/2	G 1/2	G 1	G 1	G 3/8	G 1/4	R 1/2	G 3/8	-	-	G 1/2 ¹⁹⁾	NPT 3/8	G 3/8	G 3/8	G 1/2	Ø 20	G 1/2 ¹⁹⁾	G 1/4	R 1/4	
250-250-403	G 1/2	G 1/2	G 1	G 1	G 3/8	G 1/4	R 1/2	G 3/8	-	-	G 1/2 ¹⁹⁾	NPT 3/8	G 3/8	G 3/8	G 1/2	Ø 20	G 1/2 ¹⁹⁾	G 1/4	R 1/4	
250-250-500	G 1/2	G 1/2	G 1	G 1	G 3/8	G 1/4	R 1/2	G 3/8	-	-	G 1/2 ¹⁹⁾	NPT 3/8	G 3/8	G 3/8	G 1/2	Ø 20	G 1/2 ¹⁹⁾	G 1/4	R 1/4	

17) Mechanical seal type Cartex DN P03ax to P10ax
 18) Mechanical seal type TA (MG1-G6/M3 - HRZ/M3 - 587SP-D/M3)
 19) Bearing bracket P08sx/P10ax = G 1/4

Size	1M.1	1M.2	6B	6D	7E/A	7B	8A	10E.1/A.1	10E.2 (mechanical seal), discharge cover	10A.2 (mechanical seal), seal cover	10E.2/A.2 (mechanical seal), seal cover	10E.2/A.2 (mechanical seal) ¹⁷⁾	11E.3	11E.5	13B	13D	24E/A, seal cover ¹⁸⁾	24E/A (mechanical seal type 4K), seal cover	638
250-250-503	G 1/2	G 1/2	G 1	G 1	G 3/8	G 1/4	R 1/2	G 3/8	-	-	G 1/2 ¹⁹⁾	NPT 3/8	G 3/8	G 3/8	G 1/2	Ø 20	G 1/2 ¹⁹⁾	G 1/4	R 1/4
250-250-505	G 1/2	G 1/2	G 1	G 1	G 3/8	G 1/4	R 1/2	G 3/8	-	-	G 1/2 ¹⁹⁾	NPT 3/8	G 3/8	G 3/8	G 1/2	Ø 20	G 1/2 ¹⁹⁾	G 1/4	R 1/4
250-250-630	G 1/2	G 1/2	G 1	G 1	G 3/8	G 1/4	R 1/2	G 3/8	-	-	G 1/2 ¹⁹⁾	NPT 3/8	G 3/8	G 3/8	G 1/2	Ø 20	G 1/2 ¹⁹⁾	G 1/4	R 1/4
250-250-634	G 1/2	G 1/2	G 1	G 1	G 3/8	G 1/4	R 1/2	G 3/8	-	-	G 1/2 ¹⁹⁾	NPT 3/8	G 3/8	G 3/8	G 1/2	Ø 20	G 1/2 ¹⁹⁾	G 1/4	R 1/4
300-300-400	G 1/2	G 1/2	G 1	G 1	G 3/8	G 1/4	R 1/2	G 3/8	-	-	G 1/2 ¹⁹⁾	NPT 3/8	G 3/8	G 3/8	G 1/2	Ø 20	G 1/2 ¹⁹⁾	G 1/4	R 1/4
300-300-500	G 1/2	G 1/2	G 1	G 1	G 3/8	G 1/4	R 1/2	G 3/8	-	-	G 1/2 ¹⁹⁾	NPT 3/8	G 3/8	G 3/8	G 1/2	Ø 20	G 1/2 ¹⁹⁾	G 1/4	R 1/4
300-300-503	G 1/2	G 1/2	G 1	G 1	G 3/8	G 1/4	R 1/2	G 3/8	-	-	G 1/2 ¹⁹⁾	NPT 3/8	G 3/8	G 3/8	G 1/2	Ø 20	G 1/2 ¹⁹⁾	G 1/4	R 1/4
350-350-400	G 1/2	G 1/2	G 1	G 1	G 3/8	G 1/4	R 1/2	G 3/8	-	-	G 1/2 ¹⁹⁾	NPT 3/8	G 3/8	G 3/8	G 1/2	Ø 20	G 1/2 ¹⁹⁾	G 1/4	R 1/4
350-350-500	G 1/2	G 1/2	G 1	G 1	G 3/8	G 1/4	R 1/2	G 3/8	-	-	G 1/2 ¹⁹⁾	NPT 3/8	G 3/8	G 3/8	G 1/2	Ø 20	G 1/2 ¹⁹⁾	G 1/4	R 1/4
350-350-503	G 1/2	G 1/2	G 1	G 1	G 3/8	G 1/4	R 1/2	G 3/8	-	-	G 1/2 ¹⁹⁾	NPT 3/8	G 3/8	G 3/8	G 1/2	Ø 20	G 1/2 ¹⁹⁾	G 1/4	R 1/4
350-350-504	G 1/2	G 1/2	G 1	G 1	G 3/8	G 1/4	R 1/2	G 3/8	-	-	G 1/2 ¹⁹⁾	NPT 3/8	G 3/8	G 3/8	G 1/2	Ø 20	G 1/2 ¹⁹⁾	G 1/4	R 1/4
350-350-630	G 1/2	G 1/2	G 1	G 1	G 3/8	G 1/4	R 1/2	G 3/8	-	-	G 1/2 ¹⁹⁾	NPT 3/8	G 3/8	G 3/8	G 1/2	Ø 20	G 1/2 ¹⁹⁾	G 1/4	R 1/4
350-350-633	G 1/2	G 1/2	G 1	G 1	G 3/8	G 1/4	R 1/2	G 3/8	-	-	G 1/2 ¹⁹⁾	NPT 3/8	G 3/8	G 3/8	G 1/2	Ø 20	G 1/2 ¹⁹⁾	G 1/4	R 1/4
400-400-500	G 1/2	G 1/2	G 1 1/2	G 2	G 3/8	G 1/4	R 1/2	G 3/8	-	-	G 1/2 ¹⁹⁾	NPT 3/8	G 3/8	G 3/8	G 1/2	Ø 20	G 1/2 ¹⁹⁾	G 1/4 ²⁰⁾	R 1/4
400-400-503	G 1/2	G 1/2	G 1 1/2	G 2	G 3/8	G 1/4	R 1/2	G 3/8	-	-	G 1/2 ¹⁹⁾	NPT 3/8	G 3/8	G 3/8	G 1/2	Ø 20	G 1/2 ¹⁹⁾	G 1/4 ²⁰⁾	R 1/4
400-400-533	G 1/2	G 1/2	G 1 1/2	G 2	G 3/8	G 1/4	R 1/2	G 3/8	-	-	G 1/2 ¹⁹⁾	NPT 3/8	G 3/8	G 3/8	G 1/2	Ø 20	G 1/2 ¹⁹⁾	G 1/4 ²⁰⁾	R 1/4
400-400-583	G 1/2	G 1/2	G 1 1/2	G 2	G 3/8	G 1/4	R 1/2	G 3/8	-	-	G 1/2 ¹⁹⁾	NPT 3/8	G 3/8	G 3/8	G 1/2	Ø 20	G 1/2 ¹⁹⁾	G 1/4 ²⁰⁾	R 1/4
500-400-710	G 1/2	G 1/2	G 1 1/2	G 2	G 3/8	G 1/4	R 1/2	G 3/8 ²⁰⁾	-	-	G 1/2 ¹⁹⁾ 20)	NPT 3/8 ²⁰⁾	G 3/8 ²⁰⁾	G 3/8 ²⁰⁾	G 1/2	Ø 20	G 1/2 ¹⁹⁾ 20)	G 1/4 ²⁰⁾	R 1/4
500-400-713	G 1/2	G 1/2	G 1 1/2	G 2	G 3/8	G 1/4	R 1/2	G 3/8 ²⁰⁾	-	-	G 1/2 ¹⁹⁾ 20)	NPT 3/8 ²⁰⁾	G 3/8 ²⁰⁾	G 3/8 ²⁰⁾	G 1/2	Ø 20	G 1/2 ¹⁹⁾ 20)	G 1/4 ²⁰⁾	R 1/4
500-500-544	G 1/2	G 1/2	G 1 1/2	G 2	G 3/8	G 1/4	R 1/2	G 3/8	-	-	G 1/2 ¹⁹⁾	NPT 3/8	G 3/8	G 3/8	G 1/2	Ø 20	G 1/2 ¹⁹⁾	G 1/4	R 1/4
500-500-630	G 1/2	G 1/2	G 1 1/2	G 2	G 3/8	G 1/4	R 1/2	G 3/8 ²⁰⁾	-	-	G 1/2 ¹⁹⁾ 20)	NPT 3/8 ²⁰⁾	G 3/8 ²⁰⁾	G 3/8 ²⁰⁾	G 1/2	Ø 20	G 1/2 ¹⁹⁾ 20)	G 1/4 ²⁰⁾	R 1/4
500-500-633	G 1/2	G 1/2	G 1 1/2	G 2	G 3/8	G 1/4	R 1/2	G 3/8 ²⁰⁾	-	-	G 1/2 ¹⁹⁾ 20)	NPT 3/8 ²⁰⁾	G 3/8 ²⁰⁾	G 3/8 ²⁰⁾	G 1/2	Ø 20	G 1/2 ¹⁹⁾ 20)	G 1/4 ²⁰⁾	R 1/4
500-500-634	G 1/2	G 1/2	G 1 1/2	G 2	G 3/8	G 1/4	R 1/2	G 3/8 ²⁰⁾	-	-	G 1/2 ¹⁹⁾ 20)	NPT 3/8 ²⁰⁾	G 3/8 ²⁰⁾	G 3/8 ²⁰⁾	G 1/2	Ø 20	G 1/2 ¹⁹⁾ 20)	G 1/4 ²⁰⁾	R 1/4
500-500-635	G 1/2	G 1/2	G 1 1/2	G 2	G 3/8	G 1/4	R 1/2	G 3/8 ²⁰⁾	-	-	G 1/2 ¹⁹⁾ 20)	NPT 3/8 ²⁰⁾	G 3/8 ²⁰⁾	G 3/8 ²⁰⁾	G 1/2	Ø 20	G 1/2 ¹⁹⁾ 20)	G 1/4 ²⁰⁾	R 1/4
500-500-637	G 1/2	G 1/2	G 1 1/2	G 2	G 3/8	G 1/4	R 1/2	G 3/8 ²⁰⁾	-	-	G 1/2 ¹⁹⁾ 20)	NPT 3/8 ²⁰⁾	G 3/8 ²⁰⁾	G 3/8 ²⁰⁾	G 1/2	Ø 20	G 1/2 ¹⁹⁾ 20)	G 1/4 ²⁰⁾	R 1/4
600-600-663	G 1/2	G 1/2	G 1 1/2	G 2	G 3/8	G 1/4	R 1/2	G 3/8	-	-	G 1/2 ¹⁹⁾	NPT 3/8	G 3/8	G 3/8	G 1/2	Ø 20	G 1/2 ¹⁹⁾	G 1/4	R 1/4
600-600-669	G 1/2	G 1/2	G 1 1/2	G 2	G 3/8	G 1/4	R 1/2	G 3/8	-	-	G 1/2 ¹⁹⁾	NPT 3/8	G 3/8	G 3/8	G 1/2	Ø 20	G 1/2 ¹⁹⁾	G 1/4	R 1/4
600-600-710	G 1/2	G 1/2	G 1 1/2	G 2	G 3/8	G 1/4	R 1/2	G 3/8	-	-	G 1/2 ¹⁹⁾	NPT 3/8	G 3/8	G 3/8	G 1/2	Ø 20	G 1/2 ¹⁹⁾	G 1/4	R 1/4
600-600-753	-	-	-	-	-	-	R 1 1/2	-	-	-	-	-	-	-	G 1/2	Ø 20	-	-	R 1/4
600-600-803	-	-	-	-	-	-	R 1 1/2	-	-	-	-	-	-	-	G 1/2	Ø 20	-	-	R 1/4
600-600-813	-	-	-	-	-	-	R 1 1/2	-	-	-	-	-	-	-	G 1/2	Ø 20	-	-	R 1/4
600-600-824	-	-	-	-	-	-	R 1 1/2	-	-	-	-	-	-	-	G 1/2	Ø 20	-	-	R 1/4
600-600-825	-	-	-	-	-	-	R 1 1/2	-	-	-	-	-	-	-	G 1/2	Ø 20	-	-	R 1/4
600-600-873	-	-	-	-	-	-	R 1 1/2	-	-	-	-	-	-	-	G 1/2	Ø 20	-	-	R 1/4
600-600-923	-	-	-	-	-	-	R 1 1/2	-	-	-	-	-	-	-	G 1/2	Ø 20	-	-	R 1/4
700-700-923	-	-	-	-	-	-	R 1 1/2	-	-	-	-	-	-	-	G 1/2	Ø 20	-	-	R 1/4

17) Mechanical seal type Cartex DN P03ax to P10ax
 18) Mechanical seal type TA (MG1-G6/M3 - HRZ/M3 - 587SP-D/M3)
 20) Not provided on this size with bearing bracket P16ax

	Size	1M.1	1M.2	6B	6D	7E/A	7B	8A		10E.1/A.1	10E.2 (mechanical seal), discharge cover	10A.2 (mechanical seal), seal cover		10E.2/A.2 (mechanical seal), seal cover	10E.2/A.2 (mechanical seal) ¹⁷⁾	11E.3	11E.5	13B	13D	24E/A, seal cover ¹⁸⁾	24E/A (mechanical seal type 4K), seal cover	638
700-700-929	-	-	-	-	-	-	-	R 1 1/2	-	-	-	-	-	-	-	-	-	G 1/2	Ø 20	-	-	R 1/4
700-700-953	-	-	-	-	-	-	-	R 1 1/2	-	-	-	-	-	-	-	-	-	G 1/2	Ø 20	-	-	R 1/4
700-700-959	-	-	-	-	-	-	-	R 1 1/2	-	-	-	-	-	-	-	-	-	G 1/2	Ø 20	-	-	R 1/4
800-800-934	-	-	-	-	-	-	-	R 1 1/2	-	-	-	-	-	-	-	-	-	G 1/2	Ø 20	-	-	R 1/4
800-800-935	-	-	-	-	-	-	-	R 1 1/2	-	-	-	-	-	-	-	-	-	G 1/2	Ø 20	-	-	R 1/4
800-800-939	-	-	-	-	-	-	-	R 1 1/2	-	-	-	-	-	-	-	-	-	G 1/2	Ø 20	-	-	R 1/4
800-900-883	-	-	-	-	-	-	-	R 1 1/2	-	-	-	-	-	-	-	-	-	G 1/2	Ø 20	-	-	R 1/4
900-900-1133	-	-	-	-	-	-	-	R 1 1/2	-	-	-	-	-	-	-	-	-	G 1/2	Ø 20	-	-	R 1/4
900-900-1134	-	-	-	-	-	-	-	R 1 1/2	-	-	-	-	-	-	-	-	-	G 1/2	Ø 20	-	-	R 1/4
900-900-1138	-	-	-	-	-	-	-	R 1 1/2	-	-	-	-	-	-	-	-	-	G 1/2	Ø 20	-	-	R 1/4
900-900-1139	-	-	-	-	-	-	-	R 1 1/2	-	-	-	-	-	-	-	-	-	G 1/2	Ø 20	-	-	R 1/4

17) Mechanical seal type Cartex DN P03ax to P10ax
 18) Mechanical seal type TA (MG1-G6/M3 - HRZ/M3 - 587SP-D/M3)

Coating and preservation

- Coating and preservation to KSB standard

Product benefits

- Easy to service thanks to back pull-out design
- Safe design: all pressure-retaining components cast with extra corrosion/wear allowance.
- Standard pump with suction-side wear plate in wear-resistant diagonal gap design
- High levels of efficiency with channel-type impeller; impeller with front vanes and diagonal gap; back vanes reduce axial thrust
- Dry shaft: no special materials required
- Bearing assembly in reinforced, adjustable design
- Mechanical seal fitted in conical shaft seal chamber for optimum circulation around the mechanical seal, venting and drainage of the shaft seal chamber

Acceptance tests / Warranties

- Materials testing
 - Test report 2.2 on request
- Final inspection
 - Inspection certificate 3.1 to EN 10204 on request
- Hydraulic test

The duty point of each pump is guaranteed according to ISO 9906.

The following acceptance tests can be performed and certified at extra charge:

- Performance test to ISO 9906
- NPSH test
- Other tests (e.g. vibrations, strength) on request.
- Warranties

Warranties are given within the scope of the valid delivery conditions.

General assembly drawings with list of components

Bearing brackets P03ax to P06x

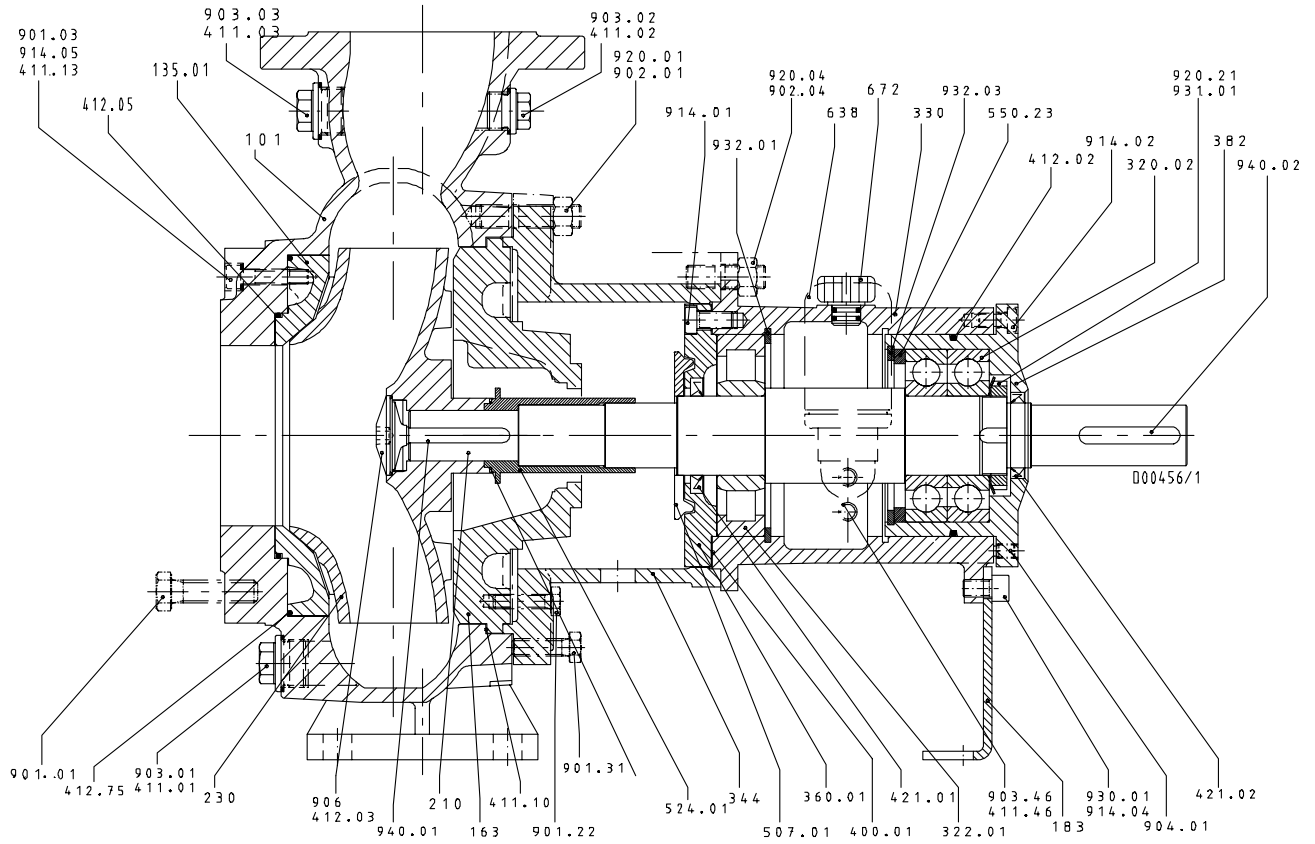

Bearing brackets P03ax to P06x

Bearing brackets P08sx to P12sx

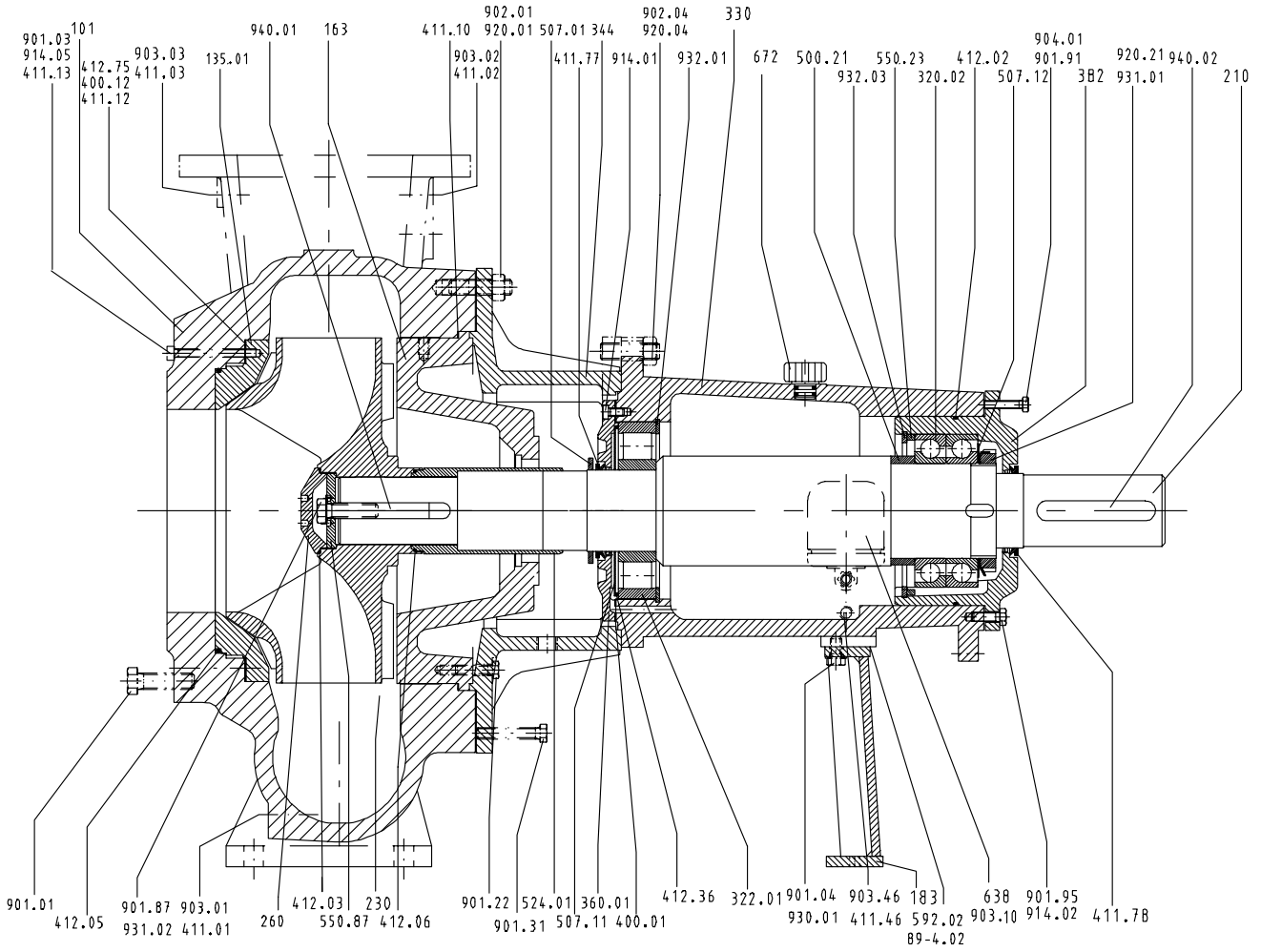

Bearing brackets P08sx to P12sx

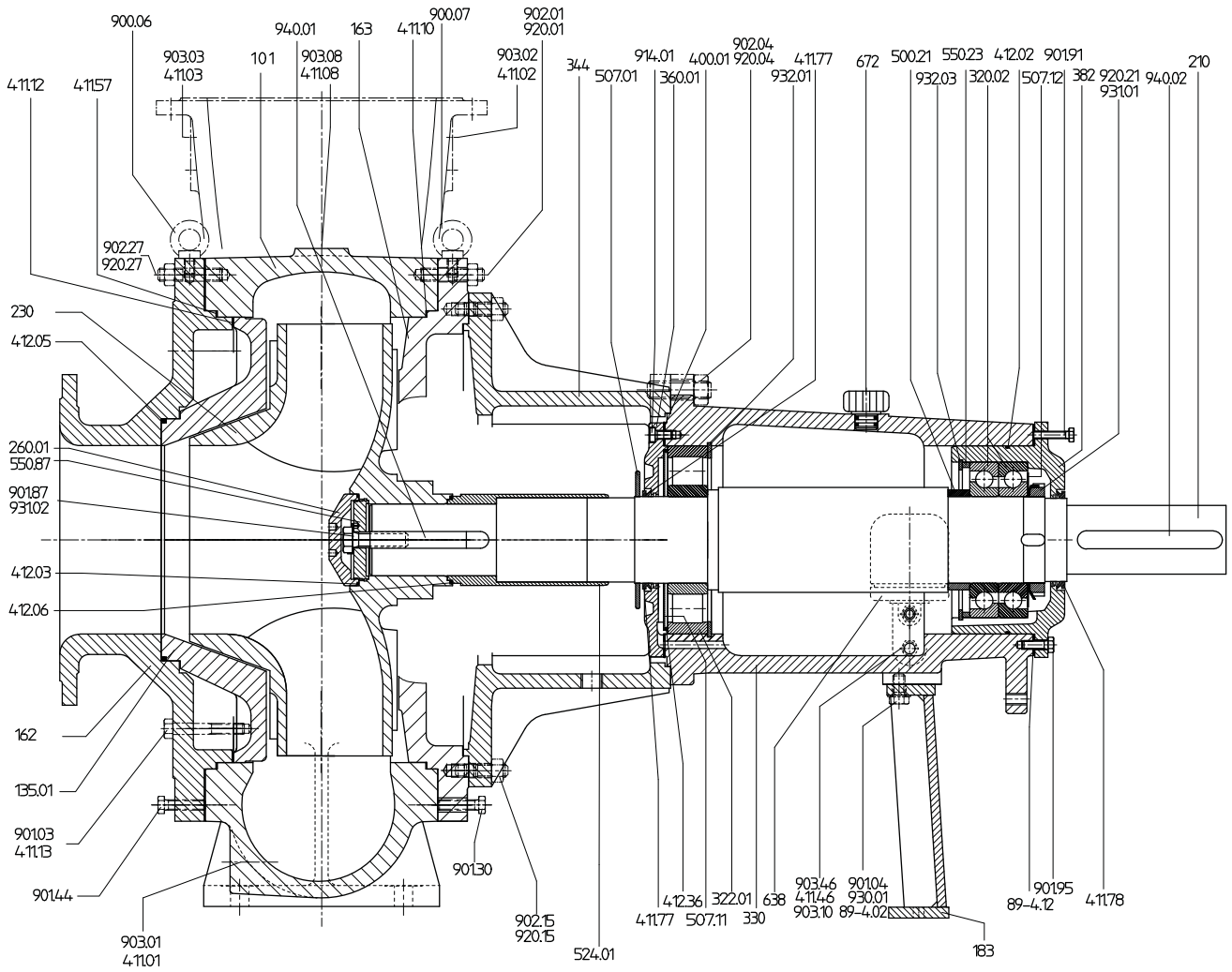

Bearing brackets P10ax to P12sx: sizes 500-400-710 and 500-400-713

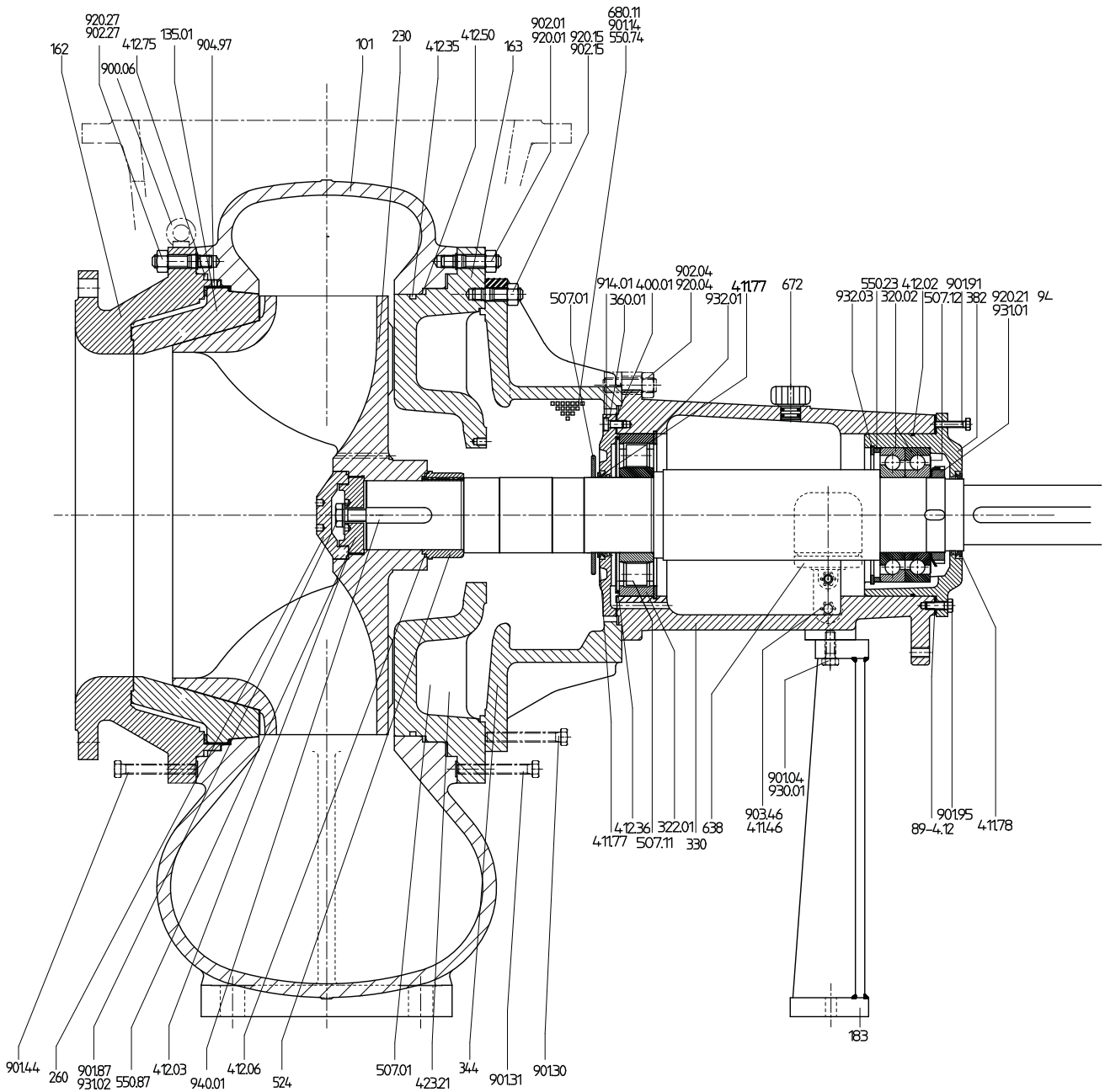

Bearing bracket P12sx: sizes 500-500-544, 600-660-663 and 600-600-669

Bearing bracket P16ax V10

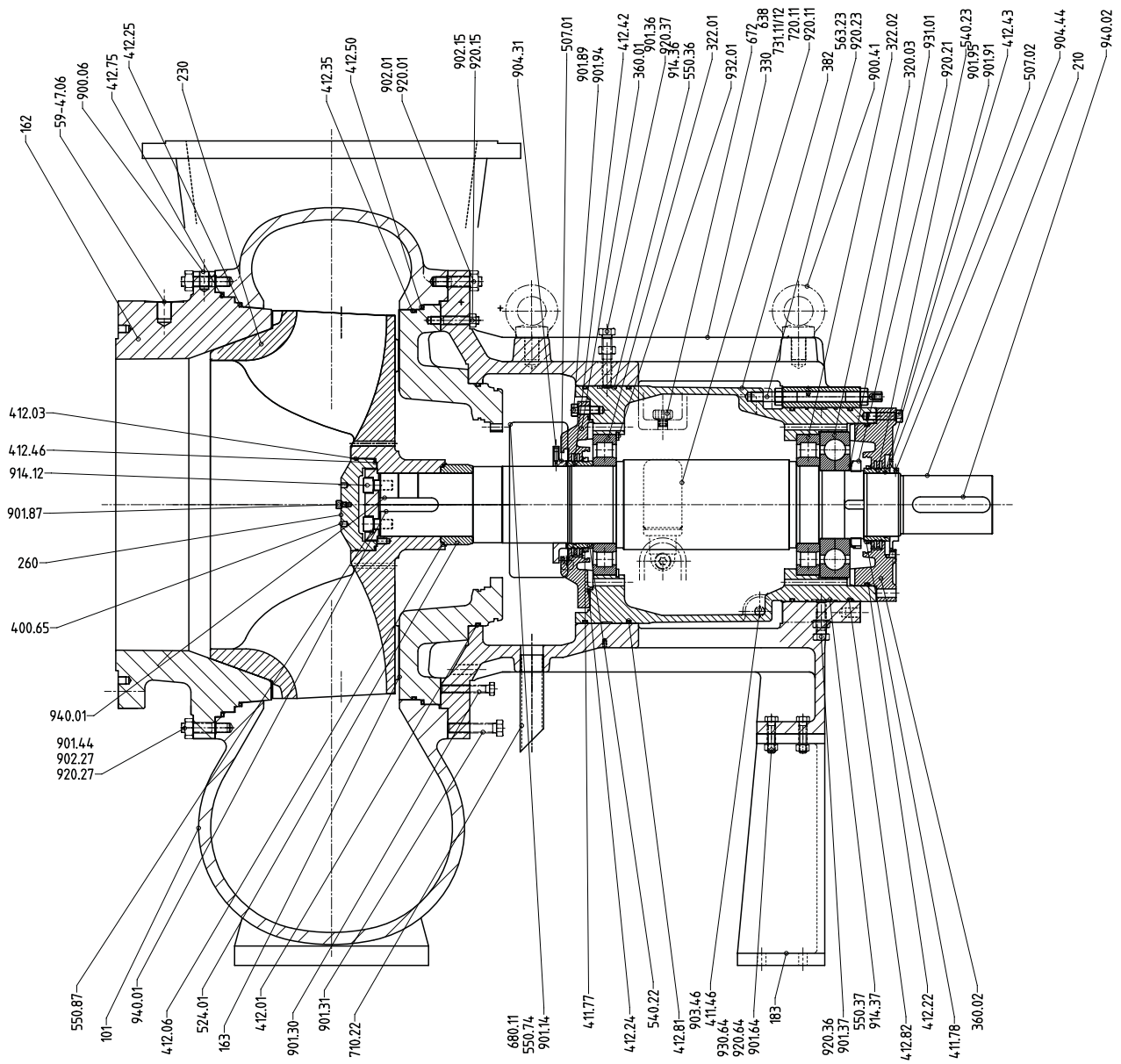

General assembly drawing of pump set with bearing bracket P16ax V10

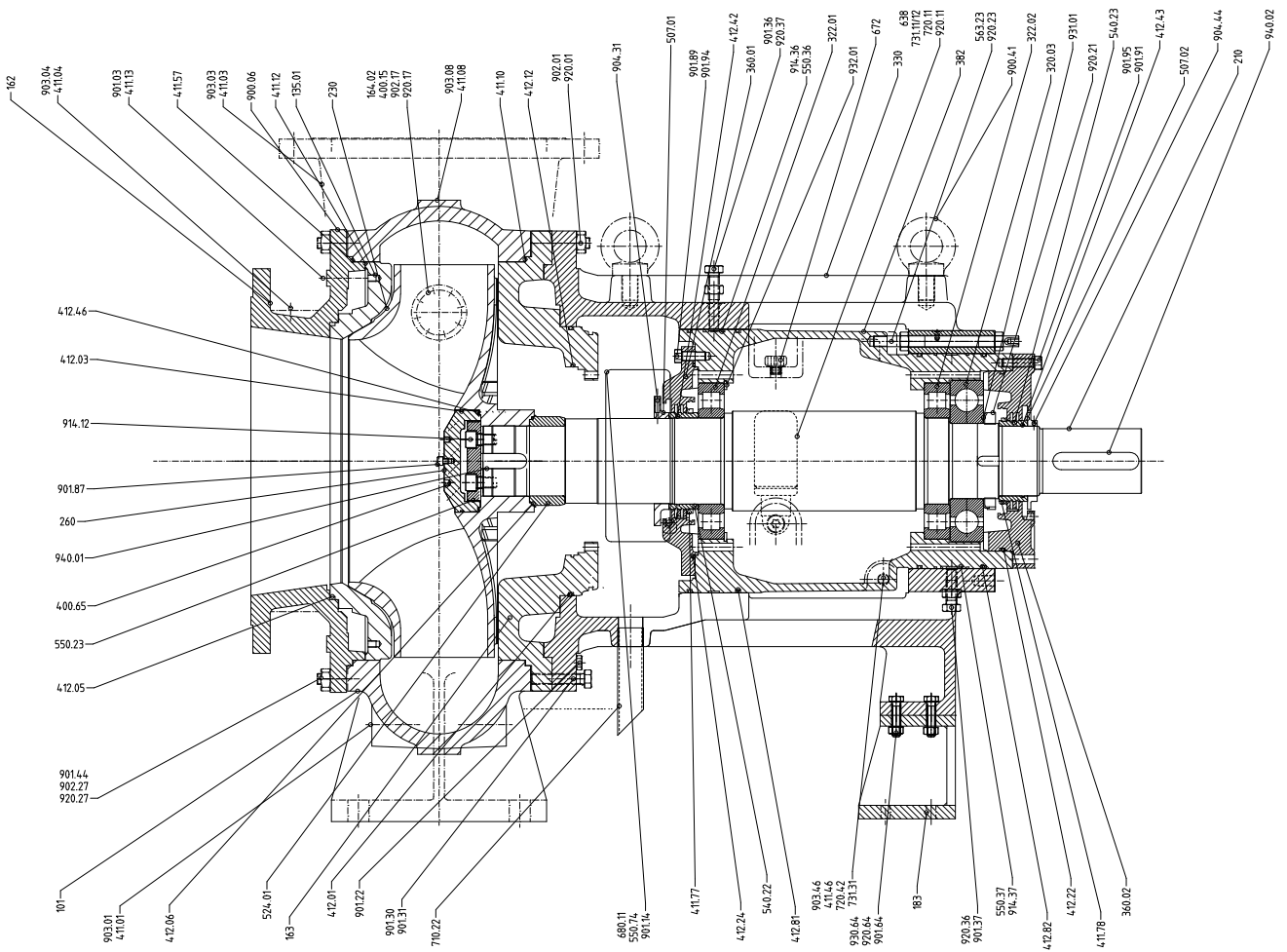

General assembly drawing of pump set with bearing bracket P16x V10 (500-400-710, 500-400-713, 500-500-633, 500-500-637)

Bearing bracket P20sx

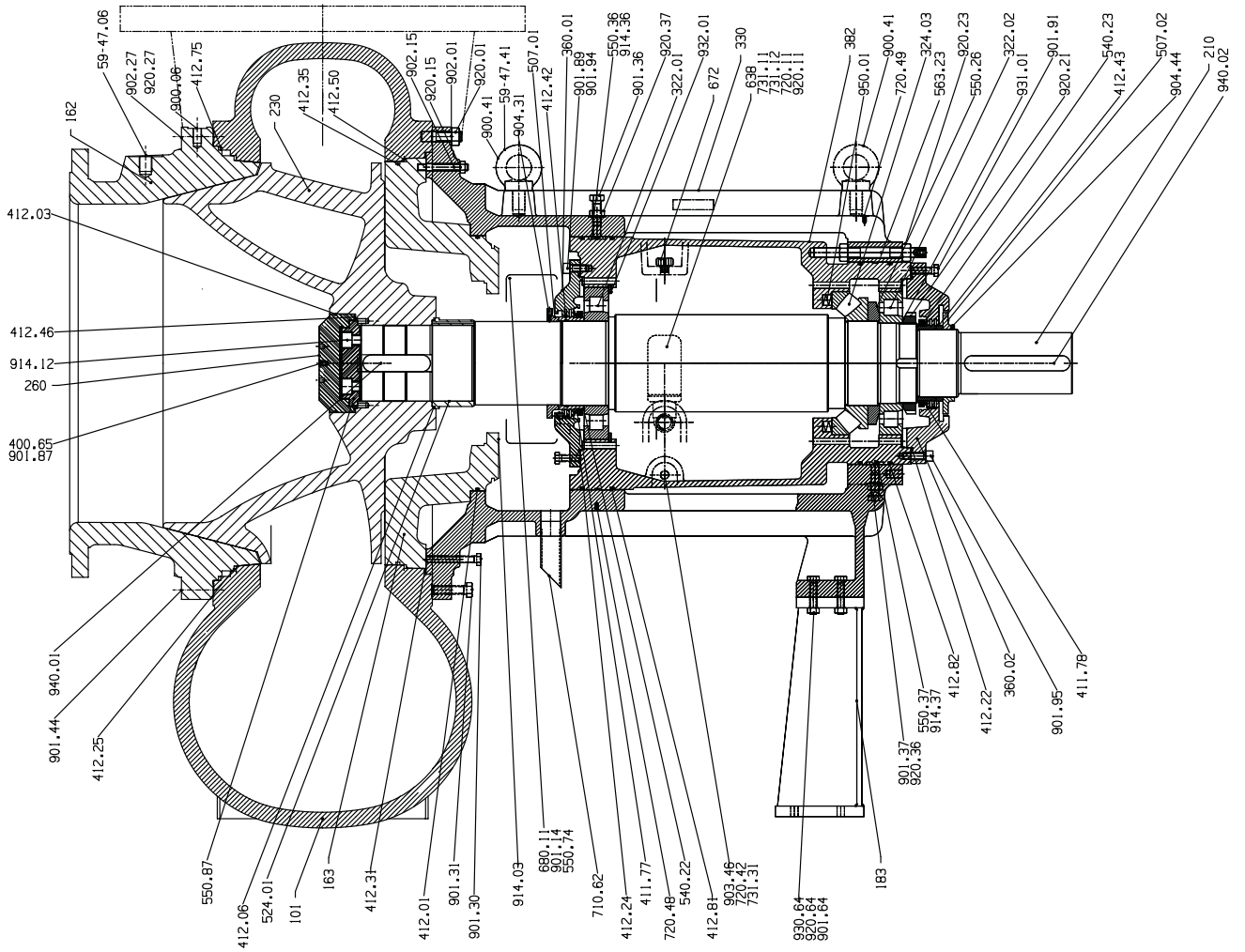

General assembly drawing of pump set with bearing bracket P20sx V10

Shaft seals

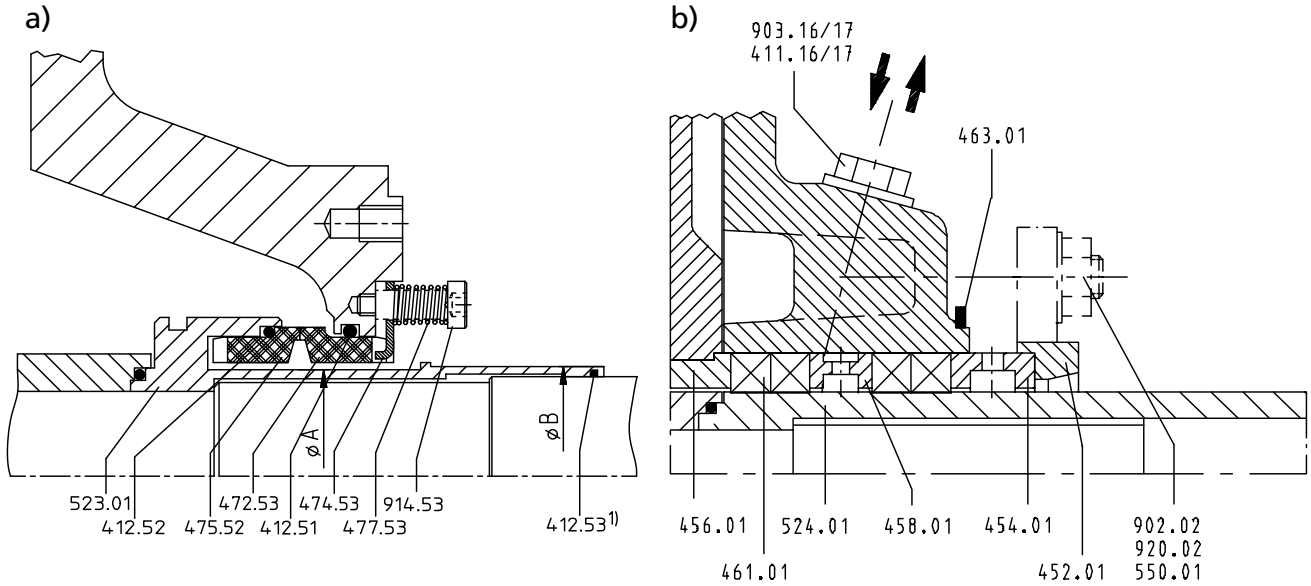

Shaft seals P03ax to P12sx: a) 4K mechanical seal; b) coolable gland packing

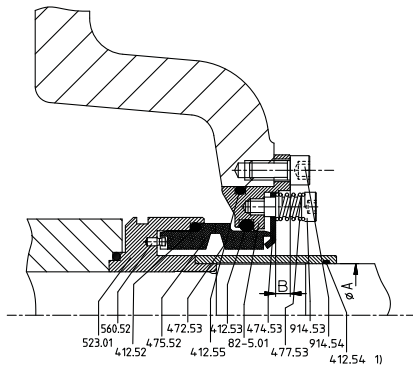

4K-120M mechanical seal²¹⁾

List of components

List of components²²⁾

Part No.	Comprising	Description
101	101	Pump casing
	411.01/.02/.03/.10 ²³⁾	Joint ring
	901.01	Hexagon head bolt
	902.01/.27	Stud
	903.01/.02/.03 ²³⁾	Screw plugs
	920.01/.27	Hexagon nut
135.01 ²⁴⁾	135.01	Wear plate
	411.12/.13/.57	Joint ring
	412.05/.75	O-ring
	901.03	Hexagon head bolt
	902.08/.90	Stud
	920.08/.90	Hexagon nut
162	914.05	Hexagon socket head cap screw
	162	Suction cover
	900.06	Eyebolt

21) Only for sizes 600-600-663 or 600-600-669

22) Depending on the design

23) If fitted

24) Sizes 250-250-0315, 300-300-0400, 350-350-0400 and 400-400-0500: casing wear ring 502.01 instead of wear plate

Part No.	Comprising	Description
	901.44	Forcing screw
	904.97	Grub screw
163	163	Discharge cover (A-type cover)
	412.35/.50	O-ring
	900.07	Eyebolt
	901.22/.30/.31	Forcing screw
	902.15	Stud
	920.15	Hexagon nut
163	163	Discharge cover with integrally cast stuffing box housing
	411.16/.17	Joint ring
	463.01	Drip plate
	550.01	Disc
	901.22	Hexagon head bolt
	902.02	Stud
	903.16/.17	Screw plug
	920.02	Nut
163	163	Discharge cover (with bolted stuffing box housing)
	400.05	Gasket
	411.26	Joint ring
	901.22	Hexagon head bolt
183	183	Support foot
	592.02	Base
	901.04	Hexagon head bolt
	914.04	Hexagon socket head cap screw
	930.01	Spring washer
	89-4.02	Shims
210	210	Shaft
	500.21	Ring
	920.21	Slotted round nut
	931.01	Lock washer
	940.01/.02	Key
230	230	Impeller
260	260	Impeller hub cap
	412.03	O-ring
	550.87	Disc
	901.87	Hexagon head bolt
	931.02	Lock washer
320.02	320.02	Angular contact ball bearing
322.01	322.01	Cylindrical roller bearing
330	330	Bearing bracket
330	330	Bearing bracket, complete
	360.01	Bearing cover
	382	Bearing carrier
	400.01	Gasket
	411.46	Joint ring
	411.77/.78	V-ring
	412.02/.36	O-ring
	421.01/.02	Lip seal
	507.01/.12	Thrower
	550.23	Support disc
	638	Constant level oiler
	672	Vent plug
	901.91/.95	Hexagon head bolt
	903.10/.46	Screw plug
	914.01/.02	Hexagon socket head cap screw
	932.01/.02/.03	Circlip
344	344	Bearing bracket lantern
	901.31	Forcing screw
	902.04	Stud
	920.04	Hexagon nut
	901.22	Hexagon head bolt
360.01	360.01	Bearing cover
	400.01	Gasket
	914.01	Hexagon socket head cap screw
	507.11	Thrower

Part No.	Comprising	Description
	412.36	O-ring
382	382	Bearing carrier
	412.02	O-ring
	89-4.12	Shims
411.77/.78	411.77/.78	V-ring
433.02	82-5.01	Adapter
	412.51/.52/.53	O-ring
	433.02	Mechanical seal, type 4K
	471	Seal cover
	472.51	Primary ring
	474.53	Thrust ring
	475.52	Mating ring
	477.53	Spring
	523.01	Shaft sleeve
	560.52	Pin
	914.53/.54	Hexagon socket head cap screw
451.01	451.01	Stuffing box housing
	400.05	Gasket
	411.16/.17/.18/.19/.26	Joint ring
	463.01	Drip plate
	550.01	Disc
	902.02	Stud
	903.16/.17/.18/.19	Screw plug
	920.01	Hexagon nut
452.01	452.01	Gland follower
454.01	454.01	Stuffing box ring, split
456.01	456.01	Neck bush
458.01	458.01	Lantern ring, split
461.01	461.01	Gland packing
59-47.06/.08/.41	59-47.06/.08/.41	Lifting lug
502.01	502.01	Casing wear ring
507.01/.11/.12	507.01/.11/.12	Thrower
524.01	524.01	Shaft protecting sleeve
	412.06	O-ring
900.06/.07/.41	900.06/.07/.41	Eyebolt
906	906	Impeller screw
	412.03	O-ring
99-9	99-9	Set of sealing elements
	400.01	Gasket
	411.01/.02/.03/.10/.12/.13/.46/.57	Joint ring
	412.02/.03/.05/.06/.35/.50/.75	O-ring

Detailed designation

Product code example

Position																																
1	2	3	4	5	6	7	8	9	10	11	12	13	14	15	16	17	18	19	20	21	22	23	24	25	26	27	28	29	30	31	32	33
K	W	P	F	1	2	5	-	1	0	0	-	0	2	5	0		G	N	N	G	1	0	P	4	X	3	N	H		5	5	4
See name plate and data sheet																							See data sheet									

Key to the designation

Position	Code	Description
1-3	Pump type	
	KWP	Type series
4	Impeller	
	K	Channel impeller
	O	Open impeller
	F	Free-flow impeller
	R	Worm-type impeller
5-17	Size	
	125	Nominal suction nozzle diameter [mm]
	100	Nominal discharge nozzle diameter [mm]

Position	Code	Description
	250	Nominal impeller diameter [mm]
18	Casing material	
	G	GJL-250
	D	NORIDUR 1.4593
	H	NORIHARD NH 15 3
	K	GJS-400-18-LT/ CeramikPolySiC
19	Impeller material	
	N	ERN
	D	NORIDUR 1.4593
	U	NORIDUR 1.4593 DAS
	H	NORIHARD NH 15 3
	K	CeramikPolySiC
	M	NORICROM 1.4475
20	Wear plate material	
	N	ERN
	D	NORIDUR 1.4593
	U	NORIDUR 1.4593 DAS
	H	NORIHARD NH 15 3
	K ²⁵⁾	CeramikPolySiC
	M	NORICROM 1.4475
21	Discharge cover material	
	G	GJL-250
	D	NORIDUR 1.4593
	H	NORIHARD NH 15 3
	M	NORICROM 1.4475
	K	CeramikPolySiC
22-23	Design variant	
	10	
	11	
24-25	Shaft seal operating mode	
	P3	Gland packing (arrangement I = 2/1/2) for barrier fluid
	P6	Gland packing (arrangement II = 1/1/3) for barrier fluid
	P4	Gland packing (arrangement IIa = -/1/3) for flushing liquid
	A	Single mechanical seal in A-type cover
	TA	Double mechanical seal in A-type cover, unpressurised
	TS	Double mechanical seal in A-type cover, with barrier fluid
	DR	Double mechanical seal in cylindrical cover, with barrier fluid
CA	Single cartridge seal	
	CBA	Double cartridge seal with barrier fluid
26	Special design	
	X	Special design
	-	Standard
27-29	Installation type	
	0	Figure 0
	3N	Fig. 3E, baseplate, non-spacer-type coupling
	3NH	Fig. 3E, baseplate, spacer-type coupling
	BH	Close-coupled, horizontal
	BV	Close-coupled, vertical
30-32	Motor rating	
	1 3 2	132 kW
	5 5	55 kW
33	Number of poles	
	2	2-pole
	4	4-pole
	6	6-pole

²⁵⁾ K defines a suction cover in GJS-400-18-LT/ CeramikPolySiC for pumps without a separate wear plate

Your local KSB representative:



PT. Sukma Tirta Persada

Ruko Asia Tropis (Ruko Grand Boulevard)

Jl. Taman Cemara Blok AT 15 No. 48

Harapan Indah, Bekasi 17214

Tel : (+62-21) 8896 9294 , 8896 9295

Fax: (+62-21) 8865 332

info@sukmatirta.com

www.sukmatirta.com



KSB Aktiengesellschaft

67225 Frankenthal • Johann-Klein-Str. 9 • 67227 Frankenthal (Germany)

Tel. +49 6233 86-0 • Fax +49 6233 86-3401

www.ksb.com